

PULLEY AND TAKE-UP CATALOG



TABLE OF CONTENTS

PULLEYS

- 3 Drum Pulley Product Range
- 4 Wing Pulley Product Range
- 5 Pulley Part Number System
- 6 Bushing Systems
- 6 Hub Design Options
- 7 XT and QD Bushing Specs
- 8 Bushing Location Dimensions
- 9 Conveyor Design Data Sheet
- 10 Conveyor Profiles
- 11 Drive Pulley Shaft Detail Worksheet
- 11 Non-Drive Pulley Assembly Details
- 12 Core Systems Pulley Data Sheet
- 13 Pulley Diameter Selection Chart
- 14 Lagging®
- 15 Chevron Pulley
- 16 Grain Elevator® Pulleys
- 17 Core Systems Design
- 18 Specialized Pulleys



APPENDIX

- 27 XT Bushing Installation
- 28 QD Bushing Installation
- 29 Bushing Maintenance & Removal
- 30 Pulley Stress Contributors
- 31 Shaft Weights & Ordering Information
- 32 Shaft Formulas
- 33 Lagging Weights
- 34 Conveyor Design Information
- 41 Terms and Conditions

TAKE-UPS

- 19 Conveyor Take-Up Frames
- 20 Telescoping Tube Take-Up (TUTT)
- 21 Wide Slot Take-Up (TUWS)
- 22 Light Duty Take-Up (TULD)
- 23 Heavy Duty Take-Up (TUHD)
- 24 Top Angle Take-Up (TUTA)
- 25 Center Pull Take-Up (TUCP)
- 26 Take-Up Interchange & Bearing Sizes

DRUM PULLEY PRODUCT RANGE

	CEMA DUTY	MINE DUTY		SUPER DUTY
		Prime® Pulley	Mine Duty	
Drum Pulleys				
Belt Style	Fabric	Fabric	Fabric	Fabric
Belt Burden	No Load	Full-Load	Full-Load	Full-Load
Starts and Stops	Infrequent	Frequent	Frequent	Frequent
Belt/Feed Characteristics	Uniformly Loaded	Non-Uniformly Loaded	Non-Uniformly Loaded	Non-Uniformly Loaded

DRUM PULLEYS



- Diameter: 8" to 60"
- Standard Face Widths: 12" to 78"

CEMA



- Diameter: 8" to 30"
- Integral Hub Diameter: Up to 30" and XT70
- Standard Face Widths: 12" to 78"

PRIME® MINE DUTY



- Diameter: 8" to 30"
- Integral Hub Diameter: Up to 30" and XT70
- Standard Face Widths: 12" to 78"

MINE DUTY 2.0



- Diameter: 8" to 30"
- Integral Hub Diameter: Up to 30" and XT70
- Standard Face Widths: 12" to 78"

SUPER DUTY

*NOTE: Other diameters and face widths available upon request. Several hub and bushing types are available with all pulleys.

WING PULLEY PRODUCT RANGE

	CEMA DUTY		MINE DUTY		SUPER DUTY	
	Standard Wing	Chevron Wing	Standard Wing	Chevron Wing	Standard Wing	Chevron Wing
Wing Pulleys						
Belt Style	Fabric	Fabric	Fabric	Fabric	Fabric	Fabric
Belt Burden	No Load	Full-Load	Full-Load	Full-Load	Full-Load	Full-Load
Starts and Stops	Infrequent	Frequent	Frequent	Frequent	Frequent	Frequent
Belt/Feed Characteristics	Uniformly Loaded	Non-Uniformly Loaded	Non-Uniformly Loaded	Non-Uniformly Loaded	Non-Uniformly Loaded	Non-Uniformly Loaded
Wing Bar Thickness	Standard: 1/4" x 1-1/2" Available: 3/8" and 5/8" x 1-1/2", 1" x 2" Round: 3/4", and 1"	Capless Wings Abrasion Resistant (AR) Steel Upgrade	Standard: 5/8" x 1-1/2" Available: 3/4" x 2", 1" x 1/2"; 3/4" Round: 1" and 1-1/2"	Capless or 1" Round, Abrasion Resistant (AR) Steel Upgrade	Standard: 3/4" x 2" Round: 1" and 1-1/2"	1-1/2" Round Abrasion Resistant (AR) Steel Upgrade

WING PULLEYS



- Diameter: 6" to 60"
- Contact bar thickness: 1/4" x 1-1/2" minimum
- Standard Face Widths: 12" to 78"

CEMA



- Diameter: 10" to 60"
- Contact bar thickness: 5/8" x 1-1/2" minimum
- Standard Face Widths: 12" to 102"

MINE DUTY 2.0



- Diameter: 10" to 60"
- Contact bar thickness: 3/4" x 2" minimum
- Standard Face Widths: 12" to 78"

SUPER DUTY

CHEVRON® PULLEYS



- Diameter: 8" to 36"
- Wing thickness: 3/4" (capless)
- Standard Face Widths: 10" to 78"

CEMA

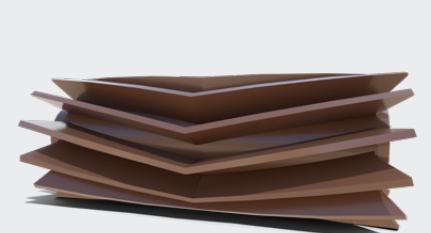

- Diameter: 10" to 48"
- Contact Bar thickness: 1" and 1-1/2" round bar, or capless
- Standard Face Widths: 12" to 78"

MINE DUTY



- Diameter: 10" to 48"
- Contact Bar thickness: 1" and 1-1/2" round bar
- Standard Face Widths: 12" to 78"

SUPER DUTY

*NOTE: Other diameters and face widths available upon request. Several hub and bushing types are available with all pulleys.

PULLEY PART NUMBER SYSTEM

SAMPLE PART NUMBER

Example: **DCEMA-1638CFXT3538H**

Pulley Style	Pulley Type	Pulley Dia.	Face Width	Face Type	Hub Type	Hub Size	Lagging Thickness	Lagging Type
---------------------	--------------------	--------------------	-------------------	------------------	-----------------	-----------------	--------------------------	---------------------

PULLEY STYLE

D = Drum
W = Wing
CHV = Chevron Wing

PULLEY TYPE

CEMA = CEMA
PM = Prime Mine Duty
M20 = Mine Duty 2.0
SUP = Super Duty
CC = CEMA Chevron Wing
M = Mine Duty Chevron Wing
MC = Mine Duty Chevron Wing Capless
MCAR = Mine Duty Chevron Wing Capless Abrasive Resistant
S = Super Chevron Wing
ELV = Elevator

DIAMETER

04" to 06" by 1" increments
08" to 20" by 2" increments
24" to 60" by 6" increments

FACE WIDTH

06" to 46" by 2" increments
51" to 66" by 3" increments

FACE TYPE

FF = Flat Face
*CF = Crown Face
*TC = Trapezoid Crown

*CF = Crown Face equals between 1/16" to 1/8" per foot crown over the full face.

*TC = Trap Crown equals 1/8" taper over 10" of the outside edges.

HUB TYPE

XT = XT
QD = QD
TL = Taper-lock (K)
KLD = Keyless Locking Device

BUSHING SIZE

XT = XT15–XT120
QD = QDSF–QDSS
TL = 2517–10085
KLD = Keyless Locking Device

LAGGING THICKNESS & TYPE

14S = 1/4" Smooth
38C = 3/8" Chevron
38H = 3/8" Herringbone
38D = 3/8" Diamond
38S = 3/8" Smooth
12C = 1/2" Chevron
12H = 1/2" Herringbone
12D = 1/2" Diamond
12S = 1/2" Smooth
58C = 5/8" Chevron
58H = 5/8" Herringbone
58D = 5/8" Diamond
58S = 5/8" Smooth
34C = 3/4" Chevron
34H = 3/4" Herringbone
34D = 3/4" Diamond
34S = 3/4" Smooth
11C = 1" Chevron
11H = 1" Herringbone
11D = 1" Diamond
11S = 1" Smooth
CL = Ceramic Lag

VCL = Vulcanized Ceramic Lag
CSL = Ceramic Slide Lag
SL = Slide Lag
U = Urethane Lag
MSHA = MSHA approved lagging (add after thickness and type)
SPIRAL = Spiral wing or drum pulley
40 = 40 Durometer (add after thickness and type)

Lagging Explanation:

12C
Lagging Type
Denominator 1
Numerator 2 = 1/2

UPGRADES: (APPEND TO PART NUMBER)

WINGS

FLAT BAR UPGRADES

38F = 3/8" x 1-1/2" flat bar
58F = 5/8" x 1-1/2" flat bar
34F = 3/4" x 2" flat bar

ROUND BAR UPGRADES

34R = 3/4" Round
10R = 1" Round
112R = 1-1/2" Round

RETAINING RING OPTION

ABRASION RESISTANT

CONTACT BARS

DRUMS

-SS = Stainless Steel
-INT = Integral End Disk Design

BUSHING SYSTEMS

XT BUSHINGS

- Designed specifically for pulley applications with 2 hubs
- 2" per foot taper (9.46° angle)
- Bolts equally spaced for uniform draw-up
- Easy removal
- Steep taper requires minimal axial movement of the hub and end disc during installation
- Reduced stress on end disc during installation
- XT bushings up to XT80 have 4-bolt, XT100 and XT120 have 6-bolt flange for clamping bushing to hub



QD BUSHINGS

- Originally designed for single hub applications such as sheaves and sprockets
- ¾" per foot taper (3.58° angle)
- Shallow taper requires more axial movement of hub and end disc during installation
- QD bushing sizes SF to JS have 3-bolt flange for clamping bushing to the hub
- QD bushing sizes MS to WS have 4-bolt flange for clamping bushing to the hub
- QD bushing size SS have 5-bolt flange for clamping bushing to the hub



TAPER-LOCK BUSHING

- Fit flush into taper-lock sprockets and pulleys
- To install, align the bushing and tighten the included set screws to the recommended torque
- Bushings have a 1-11/16" per foot taper (8° angle) and are made of steel

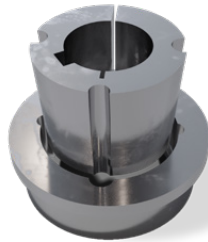

KEYLESS LOCKING DEVICE

- High torque capability
- No keyway stress concentration
- The locking assembly design includes concentric, tapered rings
- As the locking screws are torqued, the locking assembly clamps down on the shaft and expands into the hub bore, establishing a tight mechanical shrink fit



HUB DESIGN OPTIONS

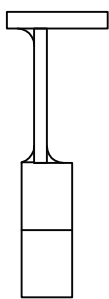

figure 1.1

CLASS ONE: WELDED HUB

- Best value in applications where high tension is not the chief concern.

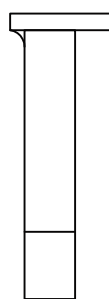

figure 1.2

CLASS TWO: INTEGRAL HUB

- One piece machined integral end disc.
- Eliminates two welds of hub to end disc, a common fatigue point.
- Optimized for XT bushings, others available upon request.

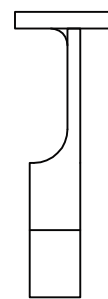

figure 1.3

CLASS THREE: PROFILE DISC

- Solid profiled end disc.
- Machined one side reduces stress and eliminates hub to end disc welds.
- Designed for Keyless Locking Devices.
- Stress free assembly without damaging effect of keyways.

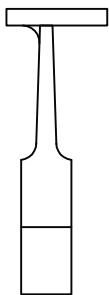

figure 1.4

CLASS FOUR: TURBINE END DISC

- One piece solid end disc.
- Machined on both sides to resemble true turbine/hourglass shape.
- Minimizes stress.
- Meets customer specific load and tensions.
- Works with various Keyless Locking Devices.

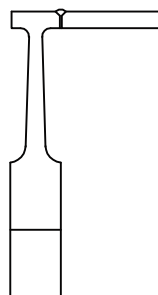

figure 1.5

CLASS FIVE: T-SECTION

- Solid end discs.
- Machined to eliminate welds on end disc.
- Joins with butt welds and rim to form "T" cross section.
- Meets customer specific load and tensions.
- Fabric and steel cable belts over 2500 PIW
- Designed for use with heaviest series of Keyless Locking Devices.

XT AND QD BUSHING SPECS

Table 2.1 XT Keyway Dimensions

BUSHING	BORE	BUSHING KEYWAY	SHAFT KEYWAY	*WEIGHT
XT15	5/8 – 7/8	3/16 X 3/32	3/16 X 3/32	1.1
	15/16 – 1-1/4	1/4 X 1/8	1/4 X 1/8	1.1
	1/5/16 – 1-3/8	5/16 X 5/32	5/16 X 5/32	1.1
	1-7/16 – 1-1/2	3/8 X 1/8	3/8 X 3/16	1.1
XT20	3/4 – 7/8	3/16 X 3/32	3/16 X 3/32	2.1
	15/16 – 1-1/4	1/4 X 1/8	1/4 X 1/8	2.1
	1-5/16 – 1-3/8	5/16 X 5/32	5/16 X 5/32	2.1
	17/16 – 1-3/4	3/8 X 3/16	3/8 X 3/16	2.1
	1-13/16 – 2	1/2 X 3/16	1/2 X 1/4	2.1
XT25	1 – 1-1/4	1/4 X 1/8	1/4 X 1/8	3.5
	1-5/16 – 1-3/8	5/16 X 5/32	5/16 X 5/32	3.5
	1-7/16 – 1-3/4	3/8 X 3/16	3/8 X 3/16	3.5
	1-13/16 – 2-1/4	1/2 X 1/4	1/2 X 1/4	3.5
	2-5/16 – 2-1/2	5/8 X 1/8	5/8 X 5/16	3.5
XT30	1-7/16 – 1-3/4	3/8 X 3/16	3/8 X 3/16	6.2
	1-13/16 – 2-1/4	1/2 X 1/4	1/2 X 1/4	6.2
	2-5/16 – 2-3/4	5/8 X 5/16	5/8 X 5/16	6.2
	2-13/16	3/4 X 3/8	3/4 X 3/8	6.2
	2-7/8 – 3	3/4 X 3/16	3/4 X 3/8	6.2
XT35	1-15/16 – 2-1/4	1/2 X 1/4	1/2 X 1/4	10.4
	2-5/16 – 2-3/4	5/8 X 5/16	5/8 X 5/16	10.4
	2-13/16 – 3-1/4	3/4 X 3/8	3/4 X 3/8	10.4
	3-5/16 – 3-3/8	7/8 X 7/16	7/8 X 7/16	10.4
	3-7/16 – 3-1/2	7/8 X 5/16	7/8 X 7/16	10.4
XT40	2-7/16 – 2-3/4	5/8 X 5/16	5/8 X 5/16	13.3
	2-13/16 – 3-1/4	3/4 X 3/8	3/4 X 3/8	13.3
	3-5/16 – 3-3/4	7/8 X 7/16	7/8 X 7/16	13.3
	3-13/16	1 X 1/2	1 X 1/2	13.3
	3-7/8 – 4	1 X 3/8	1 X 1/2	13.3
XT45	3-7/16 – 3-3/4	7/8 X 7/16	7/8 X 7/16	18.5
	3-13/16 – 4-5/16	1 X 1/2	1 X 1/2	18.5
	4-3/8 – 4-1/2	1 X 3/8	1 X 1/2	18.5
XT50	3-15/16 – 4-1/2	1 X 1/2	1 X 1/2	35.5
	4-9/16 – 5	1-1/4 X 5/8	1-1/4 X 5/8	35.5
XT60	4-15/16 – 5-1/2	1-1/4 X 5/8	1-1/4 X 5/8	48
	5-9/16 – 6	1-1/2 X 3/4	1-1/2 X 3/4	48
XT70	5-5/16 – 5-1/2	1-1/4 X 5/8	1-1/4 X 5/8	74.6
	5-9/16 – 6-1/2	1-1/2 X 3/4	1-1/2 X 3/4	74.6
	6-9/16 – 7	1-3/4 X 3/4	1-3/4 X 3/4	74.6
XT80	6-15/16 – 7-1/2	1-3/4 X 3/4	1-3/4 X 3/4	96.6
	7-9/16 – 8	2 X 3/4	2 X 3/4	96.6
XT100	8-1/2, 9	2 X 3/4	2 3/4	146
	9-7/16, 9-1/2, 10	2-1/2 X 7/8	2-1/2 X 7/8	146
XT120	10-1/2, 11	2-1/2 X 7/8	2-1/2 X 7/8	216
	11-1/2, 12	3 X 1	3 X 1	216

Table 2.2 QD Keyway Dimensions

BUSHING	BORE	BUSHING KEYWAY	SHAFT KEYWAY	*WEIGHT
SF	1/2 – 9/16	1/8 X 1/16	1/8 X 1/16	4
	5/8 – 7/8	3/16 X 3/32	3/16 X 3/32	4
	15/16 – 1-1/4	1/4 X 1/8	1/4 X 1/8	4
	1-5/16 – 1-3/8	5/16 X 5/32	5/16 X 5/32	4
	1-7/16 – 1-1-3/4	3/8 X 3/16	3/8 X 3/16	4
	1-13/16 – 2-1/4	1/2 X 1/4	1/2 X 1/4	4
	2-5/16	5/8 X 5/16	5/8 X 5/16	4
	2-3/8 – 2-1/2	5/8 X 3/16	5/8 X 5/16	4
E	1 – 1-3/8	5/16 X 5/32	5/16 X 5/32	8.7
	1-7/16 – 1-3/4	3/8 X 3/16	3/8 X 3/16	8.7
	1-13/16 – 2-1/4	1/2 X 1/4	1/2 X 1/4	8.7
	2-5/16 – 2-3/4	5/8 X 5/16	5/8 X 5/16	8.7
	2-13/16 – 2-7/8	3/4 X 3/8	3/4 X 3/8	8.7
	2-15/16	3/4 X 1/8	3/4 X 3/8	8.7
F	1-13/16 – 2-1/4	1/2 X 1/4	1/2 X 1/4	13
	2-5/16 – 2-3/4	5/8 X 5/16	5/8 X 5/16	13
	2-13/16 – 3-1/4	3/4 X 3/8	3/4 X 3/8	13
	3-5/16 – 3-7/16	7/8 X 3/16	7/8 X 7/16	13
JS	2-13/16 – 3-1/4	3/4 X 3/8	3/4 X 3/8	17.8
	3-5/16 – 3-3/4	7/8 X 7/16	7/8 X 7/16	17.8
	3 – 13/16	1 X 1/8	1 X 1/2	17.8
MS	3-7/8 – 4	1 X 1/8	1 X 1/2	17.8
	2-13/16 – 3-1/4	3/4 X 3/8	3/4 X 3/8	44.2
	3-5/16 – 3-3/4	7/8 X 7/16	7/8 X 7/16	44.2
	3-13/16 – 4-9/16	1 X 1/2	1 X 1/2	44.2
	4-11/16 – 4-3/4	1-1/4 X 5/8	1-1/4 X 5/8	44.2
NS	3-5/16 – 3-3/4	7/8 X 7/16	7/8 X 7/16	52.7
	3-13/16 – 4-1/2	1 X 1/2	1 X 1/2	52.7
	4-3/4 – 5-1/2	1-1/4 X 5/8	1-1/4 X 5/8	52.7
PS	3-15/16 – 4-1/2	1 X 1/2	1 X 1/2	84.1
	4-3/4 – 5-1/2	1-1/4 X 5/8	1-1/4 X 5/8	84.1
WS	5-15/16	1-1/2 X 3/4	1-1/2 X 3/4	84.1
	5-3/4 – 6-1/2	1-1/2 X 3/4	1-1/2 X 3/4	183
	7 – 7-1/2	1-3/4 X 3/4	1-3/4 X 3/4	183
	8	2 X 1/4	2 X 3/4	183

*Bushing weights are estimates only. Actual weights could vary from those listed.

BUSHING LOCATION DIMENSIONS

DRUM AND WING PULLEYS

A. End of pulley to face of bushing

B. Length through hub and bushing

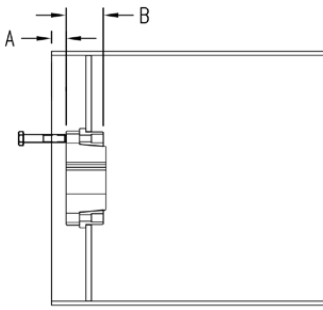

FIGURE 2.1 Bushing location drum pulley

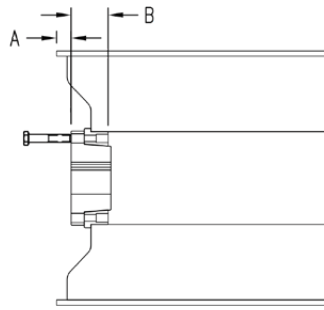

FIGURE 2.2 Bushing location wing pulleys

Table 3.1 XT Bushing Location dimensions

HUB	DIMENSIONS		BUSHING	MAX. BORE	SCREW TORQUE (IN-LBS)
	A	B			
XT15	3/8	1-1/8	XT15	1-1/2	95
XT20	13/32	1-13/32	XT20	2	200
XT25	1/2	1-7/8	XT25	2-1/2	350
XT30	1/2	2-1/16	XT30	3	550
XT35	19/32	2-15/32	XT35	3-1/2	840
XT40	5/8	2-13/16	XT40	4	1,200
XT45	11/16	3-5/16	XT45	4-1/2	1,680
XT50	13/16	3-3/4	XT50	5	3,000
XT60	7/8	4-1/8	XT60	6	4,800
XT70	1	4-11/16	XT70	7	7,200
XT80	1-1/8	5-1/8	XT80	8	9,000
XT100	1-1/8	6-3/16	XT100	10	9,000
XT120	1-1/8	7-1/16	XT120	12	9,000

Table 3.2 QD Bushing Location dimensions

HUB	DIMENSIONS		BUSHING	MAX. BORE	SCREW TORQUE (IN-LBS)
	A	B			
QDSF	5/8	2-1/16	SF	2-1/2	360
QDE	5/8	2-3/4	DE	2-15/16	720
QDF	1/2	3-3/4	F	3-7/16	904
QDJS	3/4	4-5/8	JS	4	1,620
QDMS	2-7/16	6-3/4	MS	4-3/4	2,700
QDNS	1-7/8	8-1/8	NS	5-1/4	3,600
QDPS	2-7/16	9-3/8	PS	6-1/4	5,400
QDWS	2-9/16	11-3/8	WS	8-1/8	7,200
QDSS	1-5/8	8-3/4	SS	10	9,000

Table 3.3 TAPER-LOCK Bushing Location dimensions

HUB	DIMENSIONS		BUSHING	MAX. BORE	SCREW TORQUE (IN-LBS)
	A	B			
K25	3/4	1-3/4	2517	2-1/2	430
F25	3/4	1-3/4	2517	2-1/2	430
F30	3/4	2	3020	3	800
K35	3/4	3-1/2	3535	3-1/2	1,000
K40	3/4	4	4040	4	1,700
K45	3/4	4-1/2	4545	4-1/2	2,450
K50	3/4	5	5050	5	3,100
K60	2	5	6050	6	7,820
K70	2	6	7060	7	7,820
K80	2	6-1/2	8065	8	7,820
K100	2	8-1/2	10085	10	13,700

Table 3.4 SXT Bushing location dimensions

HUB	DIMENSIONS		BUSHING	MAX. BORE	SCREW TORQUE (IN-LBS)
	A	B			
XT25	1/16	1-7/8	XT25	2-1/2	350
XT30	1/8	2-1/16	XT30	3	550
XT35	9/32	2-15/32	XT35	3-1/2	840
XT40	3/8	2-13/16	XT40	4	1,200
XT45	9/16	3-5/16	XT45	4-1/2	1,680
XT50	13/16	3-3/4	XT50	5	3,000
XT60	15/16	4-1/8	XT60	6	4,800

Table 3.5 Integral Bushing location dimensions

HUB	DIMENSIONS		BUSHING	MAX. BORE	SCREW TORQUE (IN-LBS)
	A	B			
XT15	9/16	1 1/8	XT15	1-1/2	95
XT20	21/32	1 13/32	XT20	2	200
XT25	13/16	1 7/8	XT25	2-1/2	350
XT30	7/8	2 1/16	XT30	3	550
XT35	1 1/32	2 15/32	XT35	3-1/2	840
XT40	1 1/8	2 13/16	XT40	4	1200
XT45	1 5/16	3 5/16	XT45	4-1/2	1680
XT50	1 9/16	3 3/4	XT50	5	3000
XT60	1 11/16	4 1/8	XT60	6	4800
XT70	1 15/16	4 11/16	XT70	7	7200
XT80	2 1/8	5 1/8	XT80	8	9000
XT100	2 2/8	6 3/16	XT100	10	9000
XT120	2 7/16	7 1/16	XT120	12	9000

*Note: To find XT and QD bushing installation instructions, please refer to the Appendix, page A-27 and A-28, respectively.

CONVEYOR DESIGN DATA SHEET

COMPLETE THIS FORM FOR A CUSTOMIZED CONVEYOR SYSTEM / PULLEY QUOTATION

Toll Free – 800-321-1558
Fax – 320-589-3892

BOLDED LINES INDICATE MINIMUM REQUIRED INFORMATION NECESSARY FOR PROCESSING

Date _____ **Submitted By** _____
Customer _____ **Contact Name** _____
Plant/Mine/Project _____ **Contact Phone or Email** _____

APPLICATION DATA

Operation (hours/day) _____ Ambient Temp Range (degrees) _____
Operation (days/year) _____ Altitude (ft) _____

CONVEYOR DATA

Conveyor Name/Tag _____ **Material (type & max lump size)** _____
Belt Width (in) _____ **Material Density (lbs/ft³)** _____
Bearing Centers (in) _____ Material Repose Angle (degrees) _____
Conveyor C/C Length (ft) _____ Surcharge Angle (degrees) _____
Conveyor Lift (ft) or Incline (deg) _____ **Number of Belt Scrapers/Cleaners** _____
 [if not linear, please sketch curve below] Number of Belt Plows _____
Conveyor Capacity (sTPH) _____ Top Side Idler Spacing _____
Belt Speed (FPM) _____ Trough Idler Angle & Roll Diameter _____
Motor Horsepower (if known) _____ Return Idler Angle, Spacing & Roll Diameter _____
 Take-Up Type (manual or automatic) _____ Length of Skirtboards (ft) _____
 Total Installed Counterweight (lbs) _____ Height of Material on Skirts (in) _____
 Brake or Demand HP (if known) _____ Conveyor Belt Details (if known) _____
 Motor Voltage _____ Fabric or Steel Cord _____
 Motor Hertz _____ Number of Plies & PIW (if known) _____
 Type of Soft Start _____ Covers Top x Bottom (in x in) _____
 (Electronic; VFD; Fluid Coupling; or none)

DRIVE STYLE (IF KNOWN)

Right Angle (circle 1) _____ Yes / No
 Shaft Mounted (circle 1) _____ Yes / No
 Parallel (circle 1) _____ Yes / No
 Concentric inline (circle 1) _____ Yes / No
 Output RPM= Pulley RPM _____
 Selected Pulley Diameter _____
 Shaft Diameter Through Bearing _____
 Input Connection (circle 1 below) _____
 V-Belt / C/D Flange / Coupling
 Connection to Pulley (circle 1 below) _____
 Direct Coupled / Shaft Mount / Chain or Belt Final

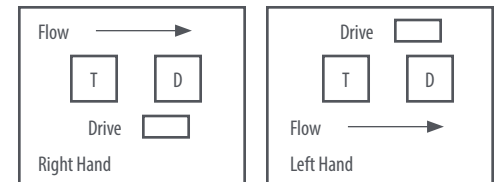

Conveyor Profile (see types 1-10 below) Circle One.

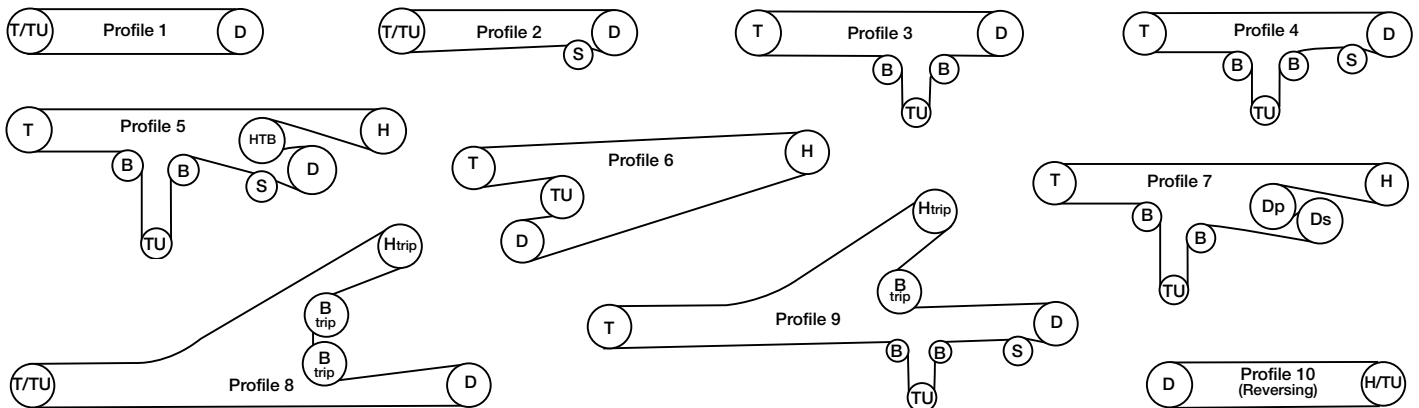

If profile differs from one shown, please sketch here:

*Refer to appendix A-40 for further details.

CONVEYOR PROFILES

PROFILE 1

Type = Head/Drive with Manual/Screw Take-Up



- Drive location = head/discharge
- Takeup location = manual at tail
- Drive snub = no

PROFILE 2

Type = Head/Drive with Snub and Manual/Screw Take-Up



- Drive location = head/discharge
- Takeup location = manual at tail
- Drive snub = yes

PROFILE 3

Type = Head/Drive with Automatic/Gravity Take-Up

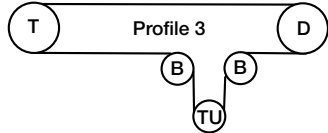

- Drive location = head/discharge
- Takeup location = automatic on return
- Drive snub = no

PROFILE 4

Type = Head/Drive with Snub and Automatic/Gravity Take-Up

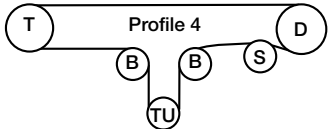

- Drive location = head/discharge
- Takeup location = automatic on return
- Drive snub = yes

PROFILE 5

Type = Wrap Drive (on return) with Snub and HT Bend and Automatic/Gravity Take-Up

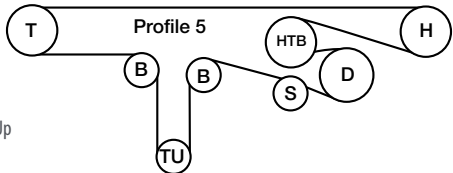

- Drive location = wrap on return
- Takeup location = gravity on return
- Drive snub = yes

PROFILE 6

Type = Wrap Drive (on return) with Manual/Screw Take-Up

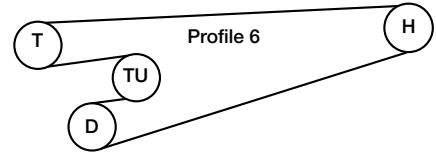

- Drive location = wrap on return
- Takeup location = manual on return
- Drive snub = no

PROFILE 7

Type = Primary and Secondary Wrap Drives (on return) and Automatic Take-Up (commonly called "S" or "Z" Drives - as used in underground mining conveyors)

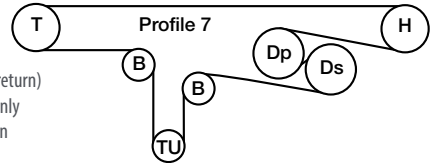

- Drive location = (2) primary and secondary wrap on return
- Takeup location = automatic on return
- Drive snub = no

PROFILE 8

Type = Tripper with Head/Drive and Manual/Screw Take-Up

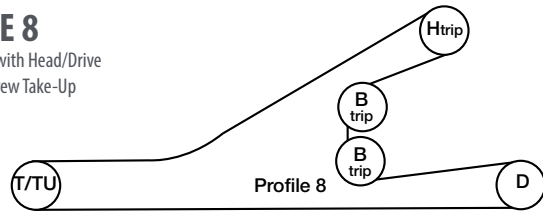

- Drive location = head/discharge
- Takeup location = manual on tail
- Drive snub = no as shown (but could be yes)

PROFILE 9

Type = Tripper with Head/Drive and Automatic/Gravity Take-Up

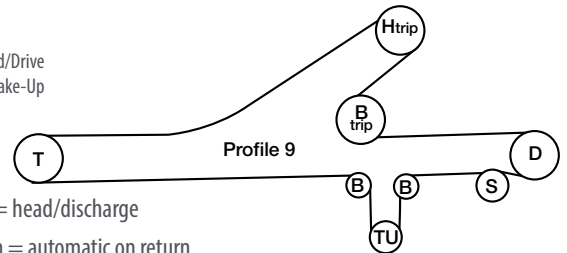

- Drive location = head/discharge
- Takeup location = automatic on return
- Drive snub = yes as shown (but could be no)

PROFILE 10

Type = Reversing/Tail Drive



- Drive location = tail
 - Takeup location = manual at head
 - Drive snub = no as shown (but could be yes)
- *NOTE: For Horizontal applications only (no lift/incline).*

KEY

D = Drive Pulley
 T = Tail Pulley
 TU = Takeup Pulley
 S = Snub Pulley
 B = Bend Pulley
 H = High Tension Pulley

DRIVE PULLEY SHAFT DETAIL WORKSHEET

Figure 3.1

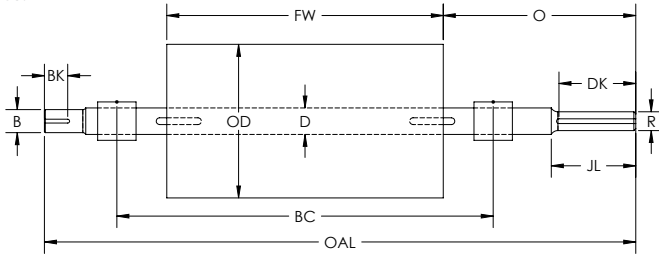

Pulley Identification _____

Belt Width _____

Pulley Diameter Dimension OD _____

Pulley Face Width Dimension FW _____

Crown Face or Flat Face _____

Hub Type _____

Lagging Thickness & Type _____

Drive Side (Right or Left) [Standing at Tail Looking to Head] _____

Pulley Offset Dimension O _____

Number of Keyseats _____

Pulley Keyseat Size _____

Shaft Material _____

Major Shaft Diameter Dimension D _____

Overall Shaft Length Dimension OAL _____

Shaft Diameter at Hubs _____

Shaft Diameter at Bearings _____

Shaft Diameter at Reducer Dimension R _____

Drive Key Size x Length Dimension DK _____

Reducer Journal Length Dimension JL _____

Shaft Diameter at Backstop Dimension B _____

Key Size x Length Dimension BK _____

Bearing Centers Dimension BC _____

Bearing Type _____

Shaft Drill and Tap (Size & Qty) _____

NON-DRIVE PULLEY ASSEMBLY DETAILS

Figure 3.2

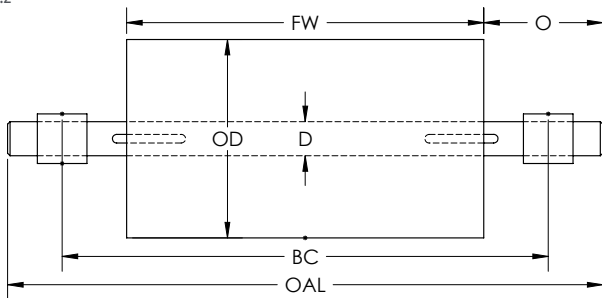

Pulley Identification _____

Belt Width _____

Drum Pulley or Wing Pulley _____

Pulley Diameter Dimension OD _____

Pulley Face Width Dimension FW _____

Crown Face or Flat Face _____

Hub Type _____

Lagging Thickness and Type _____

Pulley Offset Dimension O _____

Shaft Material _____

Major Shaft Diameter Dimension D _____

Overall Shaft Length Dimension OAL _____

Number of Keyseats _____

Keyseat Size _____

Shaft Material _____

Shaft Diameter at Hubs _____

Shaft Diameter at Bearings _____

Shaft Diameter on Ends (if stub shaft) _____

Bearing Centers Dimension BC _____

Bearing Type _____

Shaft Drill and Tap (Size & Qty) _____

CORE SYSTEMS® PULLEY DATA SHEET

COMPLETE THIS FORM FOR A CUSTOMIZED CORE SYSTEM PULLEY QUOTATION

Toll Free – 800-321-1558
 Fax – 320-589-3892

Company Name _____ Date _____ By _____
 Location _____
 Project _____
 Conveyor Information _____
 Belt: Steel Fabric Other _____ Belt Width (inches) _____
 Take Up: Screw Gravity Hyd. Other _____
 Drive Motor: HP _____ Belt Speed _____
 FPM Capacity _____ TPH _____
 Center to Center Distance _____ Lift in Feet _____

PULLEY INFO	1	2	3	4
Conveyor Identification				
Pulley Location (Drive, Tail, Snub, etc.)				
Pulley Quantity				
Pulley Type (Drum or Wing)				
Diameter X Face				
Crown or Straight				
Hub Type and Size				
Lagging-Type of Grooves				
Lagging Thickness				
Shaft Diameter through Pulley				
Shaft Diameter through Bearing				
Shaft Diameter at Drive				
Shaft Length				
Number of Keyseats				
Drive Type (Sprocket, Coupling, Shaft Mount Reducer, etc.)				

Bearing Centers

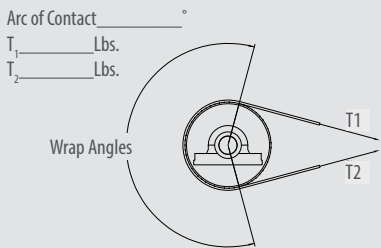

PULLEY DIAMETER SELECTION CHART

DRUM PULLEY SELECTION CHART: MAXIMUM BELT TENSION (POUNDS PER INCH OF WIDTH)

Table 4.1

ARC OF CONTACT	PULLEY DIAMETER (INCHES)													
	8	10	12	14	16	18	20	24	30	36	42	48	54	60
10°	65	80	95	120	145	175	205	260	345	430	520	605	690	775
20°	50	60	75	95	115	135	160	200	265	335	400	465	535	600
30°	45	55	65	80	100	115	140	175	230	290	345	405	460	520
40°	35	45	55	70	85	100	120	150	200	245	295	345	395	445
50°	30	40	45	60	70	85	100	130	170	215	255	300	340	385
60°	30	40	45	60	70	85	100	125	165	205	250	290	330	375
70°	30	40	50	60	75	85	105	130	175	220	260	305	350	395
80°	35	45	50	65	80	95	115	140	190	235	285	330	375	425
90°	35	45	55	70	85	100	120	150	200	255	305	355	405	455
100°	40	50	60	75	90	110	130	160	215	270	325	380	430	485
110°	45	55	65	80	100	115	140	175	230	290	345	405	460	520
120°	45	55	65	85	105	120	145	185	245	305	365	425	490	550
130°	50	60	75	95	115	135	160	200	265	335	400	465	535	600
140°	55	70	80	105	125	150	180	225	300	375	450	525	600	675
150°	60	75	90	115	140	170	200	250	335	420	505	590	670	755
160°	70	85	100	130	160	185	225	280	375	465	560	650	745	840
170°	75	95	115	145	175	205	250	310	415	520	620	725	830	930
180°	85	105	125	160	195	230	275	345	460	575	690	805	920	1035
190°	75	95	115	145	175	205	250	310	415	520	620	725	830	930
200°	70	85	100	130	160	185	225	280	375	465	560	650	745	840
210°	60	75	90	115	140	170	200	250	335	420	505	590	670	755
220°	55	70	80	105	125	150	180	225	300	375	450	525	600	675
230°	50	60	75	95	115	135	160	200	265	335	400	465	535	600
240°	45	55	65	85	105	120	145	185	245	305	365	425	490	550

WING PULLEY SELECTION CHART: MAXIMUM BELT TENSION (POUNDS PER INCH OF WIDTH)

Table 4.2

DIAMETER	PIW
8"	80
10"	100
12"	120
14"	140
16"	160

Table 4.3

DIAMETER	PIW
18"	180
20"	200
24"	240
30"	280
36"	350

CW: WRAP FACTOR

Table 4.4

TYPE OF DRIVE	ARC OF CONTACT WRAP	AUTOMATIC TAKE-UP		MANUAL TAKE-UP	
		BARE	LAGGED	BARE	LAGGED
Plain	180°	0.84	0.50	1.2	0.8
	200°	0.72	0.42	1.0	0.7
Snubbed	210°	0.66	0.38	1.0	0.7
	220°	0.62	0.35	0.9	0.6
	240°	0.54	0.30	0.8	0.6
	380°	0.23	0.11	0.5	0.3
Dual Or Tandem	420°	0.18	0.08	-	-

LAGGING

INCREASES TRACTION BETWEEN PULLEY AND BELT

MINIMIZES WEAR TO PULLEY CAUSED BY MATERIAL ABRASION

LAGGING PROMOTES CLEANING, SHEDS FUGITIVE MATERIAL

SUPERIOR VULCANIZED LAGGING PROVIDES MAXIMUM ADHESION TO THE PULLEY

MSHA APPROVED LAGGING AVAILABLE

DIDN'T SEE WHAT YOU NEED?

- Other thicknesses available on request
- Cold Bond rubber lagging available on request
- Neoprene and other lagging styles available on request

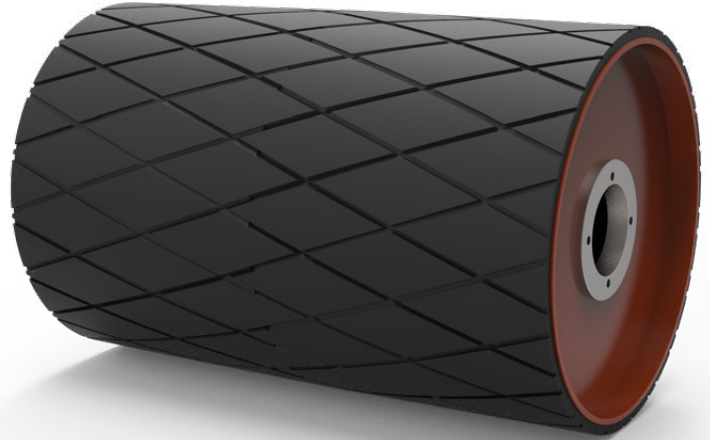

**WELD-ON
(REPLACEABLE)
CERAMIC
SLIDE-LAG**

Table 5.1 Lagging Capability

LAGGING STYLE	COMPOUND	DUROMETER	THICKNESS (IN)	PRIMARY APPLICATIONS
Chevron	SBR, SAR, MSHA	40, 60	3/8, 1/2, 5/8, 3/4, 1	Drive Pulleys, HT Pulleys, Cleans in one direction
Herringbone	SBR, SAR, MSHA	40, 60	3/8, 1/2, 5/8, 3/4, 1	Drive Pulleys, HT Pulleys, Cleans in one direction
Diamond	SBR, SAR, MSHA	40, 60	3/8, 1/2, 5/8, 3/4, 1	Drive Pulleys, HT Pulleys, Cleans in both directions
Smooth	SBR, SAR, Urethane, MSHA	40, 60	1/4, 3/8, 1/2, 5/8, 3/4, 1	T2 Pulleys, bottom side of the belt (bend, snub)
Slide Lag	SBR, SOF, Husky, MSHA	40, 60	1/2, 3/4	Drive Pulleys, Head Pulleys
Ceramic	SBR, MSHA		Based on application	High Tension, High HP Drives
Urethane	Urethane	80, 90	Based on application	Bend Pulleys, Wing Lag

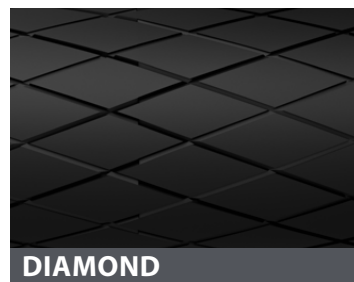

CHEVRON® PULLEY

DISPELLING MATERIAL

- Chevron pulleys are V-shaped to deflect material from becoming entrapped better than standard wings.

REDUCED WING BENDING

- The V-shaped wings deflect fugitive material out and away, making it difficult to get rocks wedged between wings and belt causing wing tipping and belt damage.

EXTENDS LIFE OF CONVEYOR BELT

- Less material entrapment that punctures belt.
- Significantly reduced beating action due to the Chevron pulley's wings being in constant contact with the belt.
- Testing provided by Fenner Dunlop®.

QUIET

- A standard wing pulley averages 120 dB while the Chevron pulley is only 70 dB. The difference is comparable of a jet engine to a vacuum.

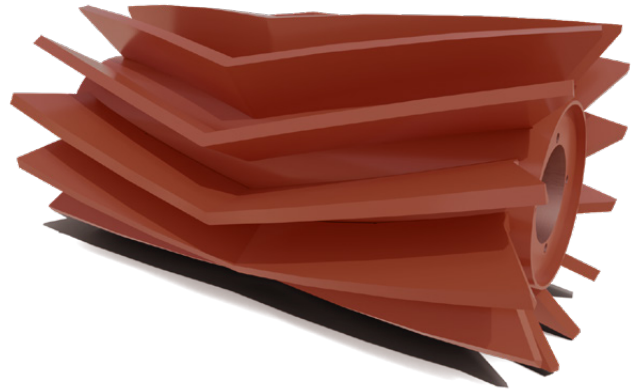

Table 6.1 Chevron pulley specs

	CEMA DUTY	MINE DUTY	SUPER DUTY
Wear Bar Thickness	NA	1" Round Bar*	1-1/2" Round Bar*
Wing Thickness	3/4"	1/4" to 5/16"	3/8"
Diameter	8" to 36"	10" to 48"	10" to 48"
Face Width	10" to 78"	12" to 78"	12" to 78"

*Available in abrasion resistant steel



GRAIN ELEVATOR PULLEYS

PULLEYS

- Head pulleys
 - ↳ Steel
 - ↳ Vulcanized lagging
 - ↳ Static conductive / oil resistant / flame resistant slide lagging
- Available bolt on lagging
- Boot pulleys
- Chevron Pulleys
 - ↳ Optional contact ring
 - ↳ Round bar or flat contact ring
 - ↳ Available with 1" or 1-1/2" round contact bars
- Enclosed belt Chevron Pulley
- Standard wing
- Spiral wrapped wing

WHY CHEVRON PULLEY?

- Original v-shaped wing design
- Quieter operation with wing design maintaining constant contact with the belt
- Less vibration extends bearing life and reduces dust
- Wing extensions direct grain back onto belt
- Easier on belting and splices
- Sheds material more freely

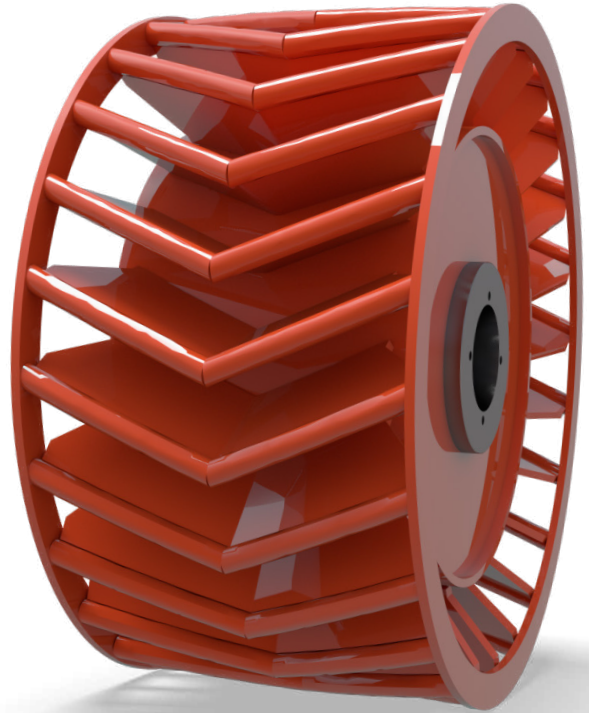

Chevron® Boot Pulley with Sensor Ring



HEAD PULLEY (SLIDE LAGGING)



BOLT ON SLIDE LAGGING

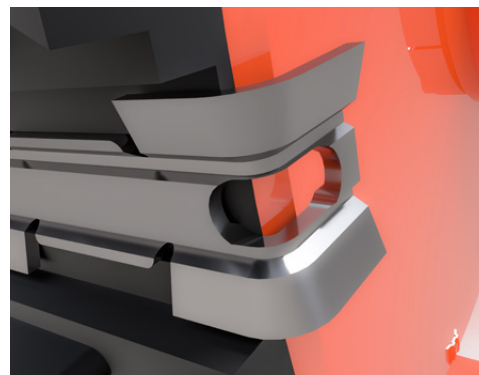

BEND OVER TABS



SINGLE DISC PULLEY

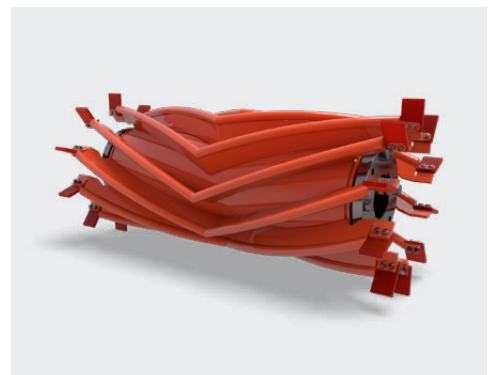

ENCLOSED BELT CHEVRON® PULLEY

CORE SYSTEMS® DESIGN

APPLICATION ENGINEERED

- Ensures power requirements are met
- Rust prevention treatment on shaft

MANUFACTURING CAPABILITIES

- Certified by American Welding Society (AWS D1.1)
- On-site weld inspection, nondestructive testing and x-rays
- Machined rims, lagging, balancing and thermal stress relief
- Keyless locking assemblies create tightest fit around shaft
- Reference page 14 for lagging capabilities

AVAILABLE ON REQUEST

- Assembly drawings
- Industry leading brands of power transmission components

PRE-ASSEMBLED PACKAGES

- Eliminates the headaches of on-site assembly
- Reduces installation time

FAST SERVICE AND SUPPORT

- Expedited services available
- **24/7 emergency support**
- Nationwide distribution
- Two-year warranty

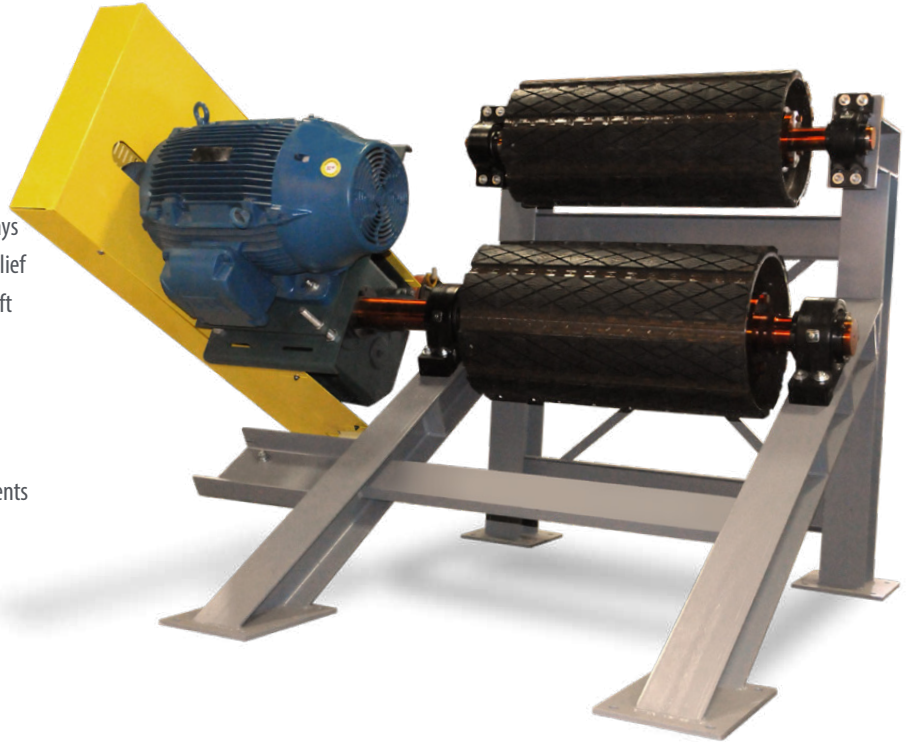

IN APPLICATION



DUAL DRIVE ASSEMBLY

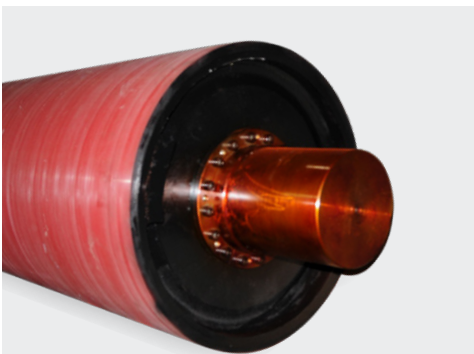

TURBINE END DISC / KEYLESS LOCKING DEVICE

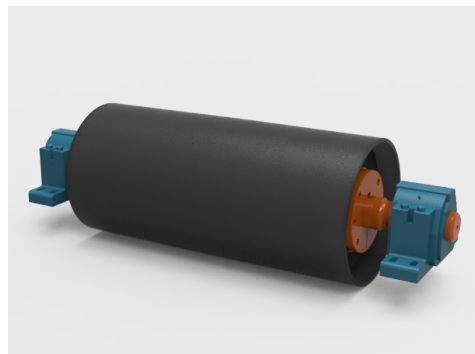

HEAD END DRIVE ASSEMBLY

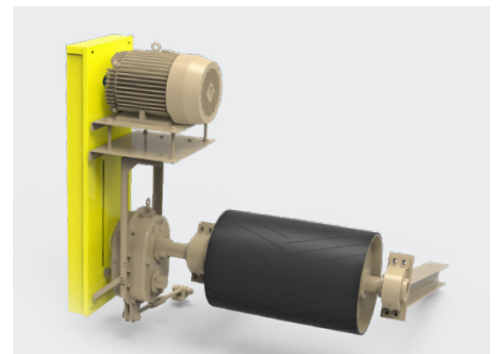

SHAFT MOUNT DRIVE ASSEMBLY

SPECIALIZED PULLEYS

SPIRAL DRUM PULLEY

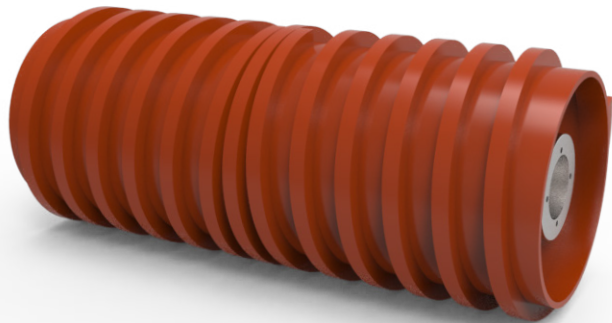

SPIRAL WING PULLEY

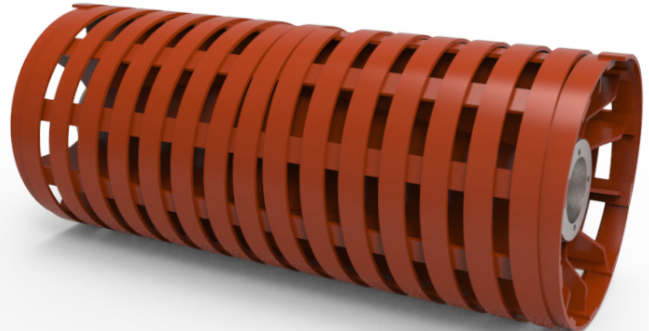

BEATER BAR



ROUND BAR SUPER WING PULLEY

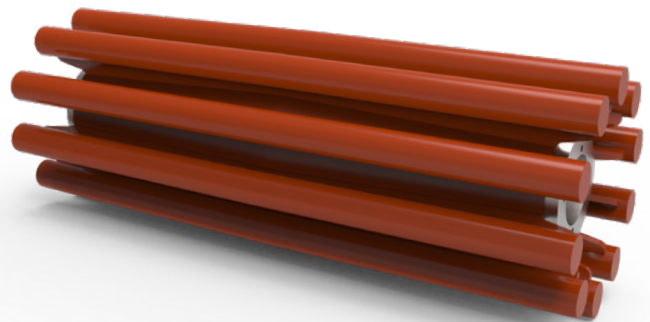

DEFLECTION WHEEL



DEAD SHAFT PULLEYS

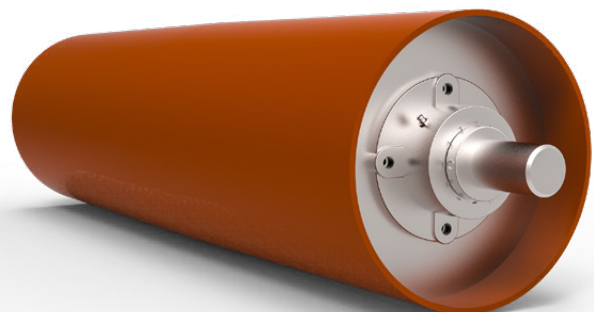

CONVEYOR TAKE-UP FRAMES

TELESCOPING TUBE TAKE-UP

Part Number Example:

TUTT-350-12

Take Up Style + **Size of Frame** + Travel Distance
(Telescoping Tube Take-Up Frame 300 Series with 12" of Travel)



WIDE SLOT TAKE-UP

Part Number Example:

TUWS-200-18

Take Up Style + **Size of Frame** + Travel Distance
(Wide Slot Take-Up Frame 200 Series with 18" of Travel)

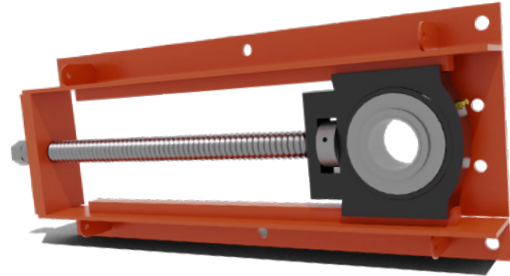

TOP ANGLE TAKE-UP

Part Number Example:

TUTA-400-24

Take Up Style + **Size of Frame** + Travel Distance
(Top Angle Take-Up Frame 400 Series with 24" of Travel)

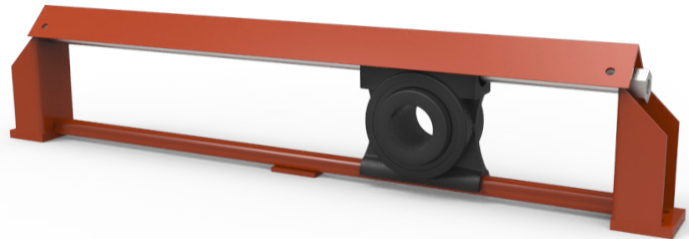

LIGHT DUTY TAKE-UP

Part Number Example:

TULD-500-24

Take Up Style + **Size of Frame** + Travel Distance
(Light Duty Take-Up Frame 250 Series with 30" of Travel)



HEAVY DUTY TAKE-UP

Part Number Example:

TUHD-350-60

Take Up Style + **Size of Frame** + Travel Distance
(Heavy Duty Take-Up Frame 350 Series with 36" of Travel)



CENTER PULL TAKE-UP

Part Number Example:

TUCP-515-36

Take Up Style + **Size of Frame** + Travel Distance
(Center Pull Take-Up Frame 515 Series with 36" of Travel)



TELESCOPING TUBE TAKE-UP (TUTT)

Figure 4.1 TUTT Drawings

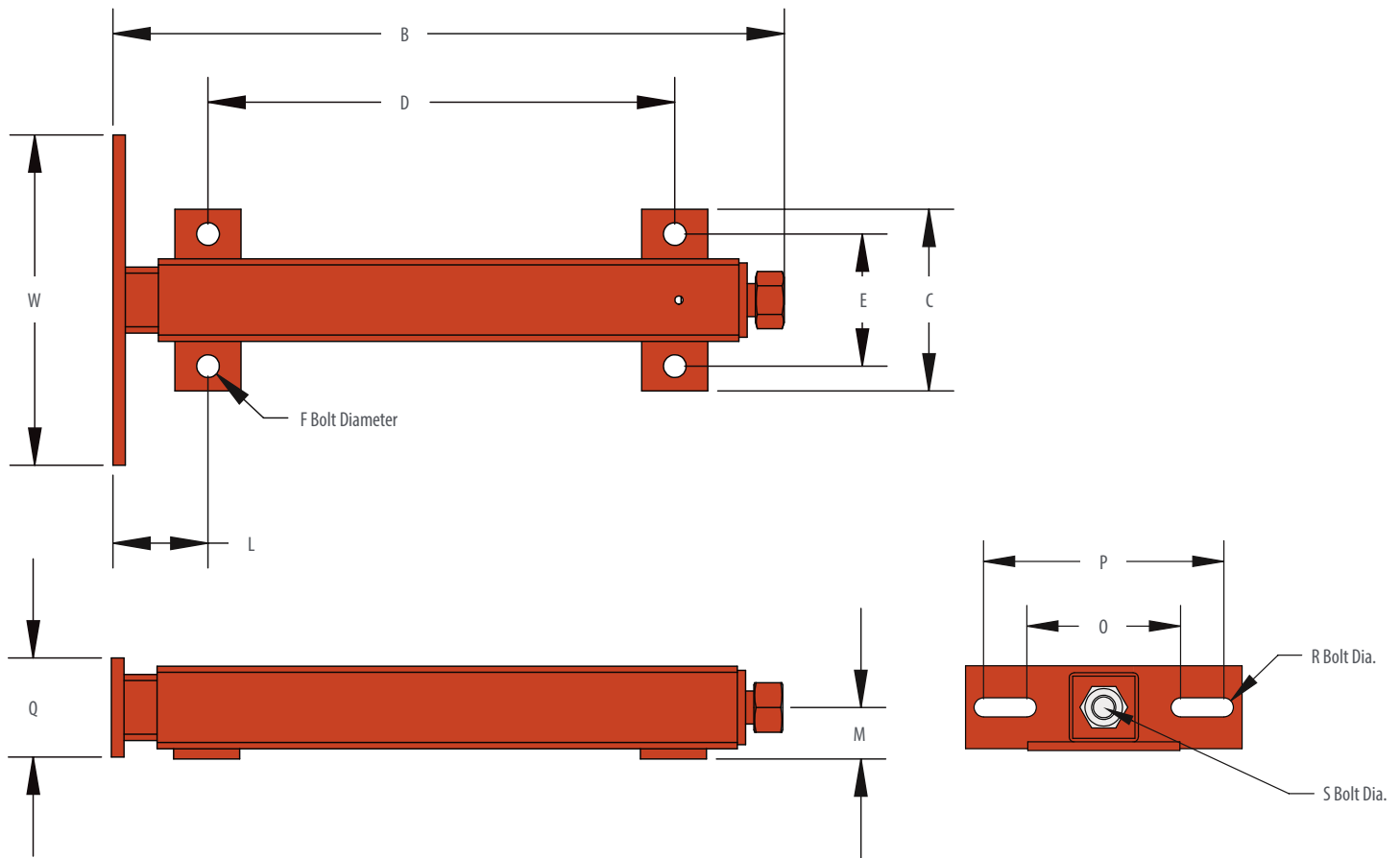

Table 7.1 TUTT Dimensions

PART NUMBER	TRAVEL	WT. (LBS)	B	C	D	E	F BOLT DIA.	L	M	O	P	Q	R BOLT DIA.	S ROD DIA.	W	BEARING RANGE
TUTT-100-3	3	6	7-7/16		3-9/16											1/2"
TUTT-100-6	6	9	10-15/16	3-11/16	7-1/16	2-5/8	1/2	1-5/8	1-3/16	3-7/16	4-7/8	1-1/2	3/8	5/8	5-1/4	TO
TUTT-100-9	9	12	14-15/16		11-1/16											1"
TUTT-250-3	3	8	8-11/16		4-3/8											3/4"
TUTT-250-6	6	11	11-1/2	4	7-3/8	3	1/2	1-7/8	1-5/16	3-3/4	5-3/4	2	1/2	3/4	7	TO
TUTT-250-9	9	13	14-11/16		10-3/8											1-3/4"
TUTT-250-12	12	15	17-9/16		13-3/8											
TUTT-300-6	6	15	11-1/16		6-1/8											1-3/4"
TUTT-300-9	9	19	15-1/16	5-1/2	10-1/8	4	5/8	2	1-9/16	5-9/16	8-11/16	2-3/4	5/8	1	10	TO
TUTT-300-12	12	24	19-1/16		14-1/8											2-15/16"
TUTT-300-18	18	31	26		21-1/8											
TUTT-350-9	9	28	18-7/8		12-5/8 to 13											1-3/4"
TUTT-350-12	12	31	21-7/8		15-5/8 to 16	4-1/2	5/8	2-1/8	1-13/16	5-9/16	8-11/16	3	3/4	1	10	TO
TUTT-350-18	18	39	27-7/8	6	21-5/8 to 22											2-15/16"
TUTT-350-24	24	47	33-7/8		27-5/8 to 28											
TUTT-400-12	12	54	27-5/8		20											2-7/16"
TUTT-400-18	18	64	33-5/8		26											TO
TUTT-400-24	24	75	39-5/8	7-1/2	32	5-1/2	3/4	2-5/16	2-1/8	8	11-3/4	3-1/2	3/4	1-1/2	14	3-1/2"
TUTT-400-36	36	97	51-5/8		44											
TUTT-400-48	48	118	63-5/8		56											
TUTT-500-18	18	206	41-3/8		31											
TUTT-500-24	24	234	47-3/8		37					Made To Order	Made To Order	7	Made To Order	2	20	3-11/16"
TUTT-500-36	36	289	59-3/8	11-1/2	49	9	1	4-5/8	3-1/2							TO
TUTT-500-48	48	345	71-3/8		61											6"
TUTT-500-60	60	400	83-3/8		73											

Add "D" to the end of part number for a direct weld. No bolt flange or foot plate is included.

WIDE SLOT TAKE-UP (TUWS)

Figure 4.2 TUWS Drawings

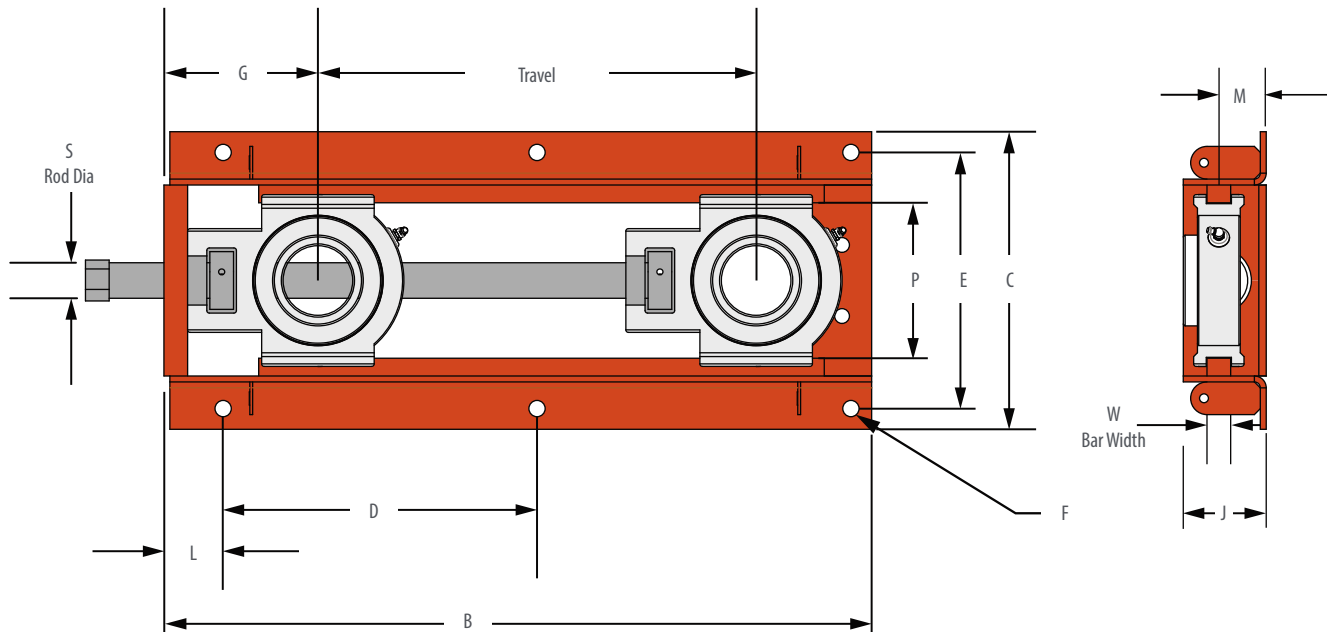

Table 7.2 TUWS Dimensions

PART NUMBER	TRAVEL DISTANCE	WT. (LBS)	B	C	D	E	F BOLT DIA.	# OF BOLTS	G	J	L	M	P	S ROD DIA.	W BAR WIDTH
TUWS-100-1.5	1-1/2	6	7-1/2		5-3/8			4							
TUWS-100-3	3	7	9		6-7/8			4							
TUWS-100-6	6	9	12	7-5/16	4-15/16			6	3-1/8	2	1	1-1/16	3	5/8	1/2
TUWS-100-9	9	11	15		6-7/16			6							
TUWS-100-12	12	13	18		7-15/16			6							
TUWS-150-3	3	8	9-1/8		6-7/16			4							
TUWS-150-6	6	10	12-1/8		9-7/16			4							
TUWS-150-9	9	12	15-1/8	7-13/16	6-7/32	6-1/16	7/16	6	3-1/2	2	1	1-1/4	3-9/16	3/4	1/2
TUWS-150-12	12	15	18-1/8		7-23/32			6							
TUWS-150-18	18	17	24-1/8		10-23/32			6							
TUWS-200-3	3	13	10-3/4		8-1/2			4							
TUWS-200-6	6	15	13-3/4		11-1/2			4							
TUWS-200-9	9	18	16-3/4	8-9/16	7-1/4	7-5/16	1/2	6	4-1/4	2-1/2	1-1/8	1-7/16	4-1/16	1	5/8
TUWS-200-12	12	20	19-3/4		8-3/4			6							
TUWS-200-18	18	25	25-3/4		11-3/4			6							
TUWS-200-24	24	29	31-3/4		14-3/4			6							
TUWS-250-3	3	19	11-3/4		9-1/2			4							
TUWS-250-6	6	22	14-3/4		12-1/2			4							
TUWS-250-9	9	25	17-3/4		15-1/2			4							
TUWS-250-12	12	28	20-3/4	10-11/16	9-1/4	8-5/8	9/16	6	5-1/4	3	1-1/8	1-1/2	5-3/16	1-1/4	1
TUWS-250-18	18	35	26-3/4		12-1/4			6							
TUWS-250-24	24	41	32-3/4		15-1/4			6							
TUWS-250-30	30	47	38-3/4		18-1/4			6							
TUWS-300-9	9	34	20-7/8		17-1/2			4							
TUWS-300-12	12	38	23-7/8		10-1/4			6							
TUWS-300-18	18	44	29-7/8	12	13-1/4	10-1/4	5/8	6	6-3/8	3-1/2	2-1/2	2	6	1-1/2	1
TUWS-300-24	24	54	35-7/8		16-1/4			6							
TUWS-300-30	30	61	41-7/8		19-1/4			6							
TUWS-350-9	9	35	20-7/8		17-1/2			4							
TUWS-350-12	12	39	23-7/8		10-1/4			6							
TUWS-350-18	18	46	29-7/8	12-9/16	13-1/4	10-13/16	5/8	6	6-1/2	3-1/2	2-1/2	2	6-9/16	1-1/2	1
TUWS-350-24	24	54	35-7/8		16-1/4			6							
TUWS-350-30	30	62	41-7/8		19-1/4			6							

To order a wideslot take-up cover add "C" at the end of the part #.
 Example TUWS-350-18C, (This only orders a cover, not the take-up.)

LIGHT DUTY TAKE-UP (TULD)

Figure 4.3 TULD Drawings

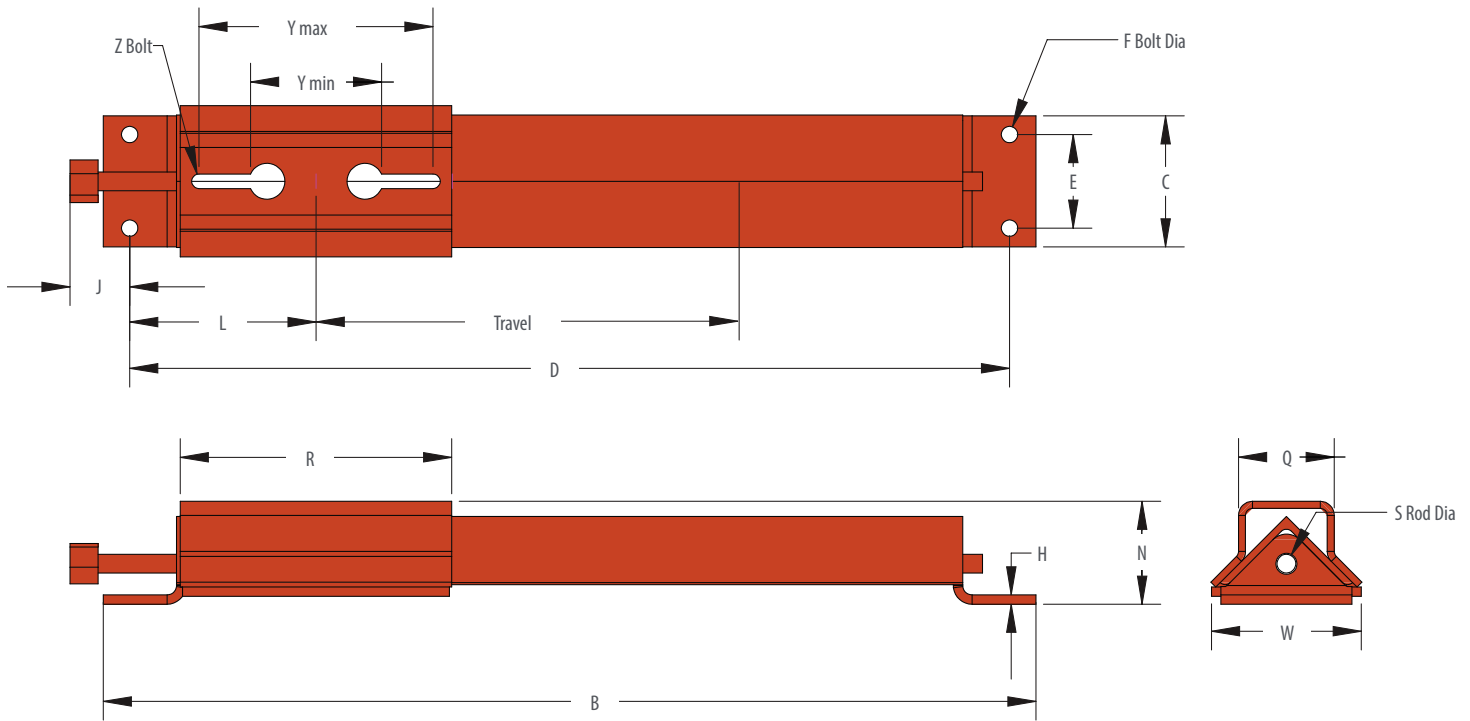

Table 7.3 TULD Dimensions

PART NUMBER	TRAVEL	WT (LBS)	B	C	D	E	F BOLT DIA	H	J	L	N	Q	R	S ROD DIA	W	Y (BOLT TO BOLT)		Z BOLT DIA X LENGTH
																MIN	MAX	
TULD-100-6	6	12	19-1/2	3 1/2	18													
TULD-100-9	9	12	22		20-1/2													
TULD-100-12	12	14	25		23-1/2	2-1/2	3/8	1/4	1-3/4	4-3/8	2-3/4	2-3/8	5-3/4	3/4	3-5/8	2-7/8	4-3/8	3/8 x 1-1/2
TULD-100-18	18	17	33-1/2		32													
TULD-200-6	6	13	19-1/2	3 1/2	18													
TULD-200-9	9	14	22		20-1/2													
TULD-200-12	12	15	25		23-1/2	2-1/2	1/2	1/4	1-3/4	5-3/8	2-3/4	2-3/8	7-3/4	3/4	3-5/8	4-1/16	6-1/4	1/2 x 2-1/2
TULD-200-18	18	18	33-1/2		32													
TULD-200-24	24	20	39-1/2		38													
TULD-300-6	6	14	22-1/4	3 1/2	20-3/4													
TULD-300-12	12	17	28-1/4		26-3/4													
TULD-300-18	18	19	34-1/4		32-3/4	2-1/2	1/2	1/4	1-3/4	6	2-3/4	2-3/8	9	3/4	3-5/8	5-3/16	7-3/8	5/8 x 3
TULD-300-24	24	21	40-1/4		38-3/4													
TULD-300-30	30	23	46-1/4		44-3/4													
TULD-400-6	6	17	22-1/4	4 3/4	20-1/2													
TULD-400-12	12	20	28-1/4		26-1/2													
TULD-400-18	18	23	34-1/4		32-1/2													
TULD-400-24	24	25	40-1/4		38-1/2	3	5/8	5/16	1-7/8	6-1/8	3-3/16	2-13/16	9-3/8	3/4	4-3/8	5-3/16	7-7/8	5/8 x 3
TULD-400-30	30	27	46-1/4		44-1/2													
TULD-400-36	36	30	52-1/4		50-1/2													
TULD-450-12	12	37	33-1/4		31-1/2													
TULD-450-18	18	40	39-1/4		37-1/2													
TULD-450-24	24	44	45-1/4		43-1/2													
TULD-450-30	30	48	51-1/4	5	49-1/2	3	3/4	5/16	2-3/16	8-1/16	4-1/8	3-1/2	13-1/4	1	5-1/8	6-13/16	11-1/2	3/4 x 3 1/2
TULD-450-36	36	51	57-1/4		55-1/2													
TULD-450-42	42	56	63-1/4		61-1/2													
TULD-450-48	48	59	69-1/4		67-1/2													
TULD-500-12	12	37	33-1/4		31-1/2													
TULD-500-18	18	40	39-1/4		37-1/2													
TULD-500-24	24	44	45-1/4		43-1/2													
TULD-500-30	30	48	51-1/4	5	49-1/2	3	3/4	5/16	2-3/16	8-1/8	4-1/8	3-1/2	13-3/8	1	5-1/4	7-1/16	11-5/8	7/8 x 4
TULD-500-36	36	52	57-1/4		55-1/2													
TULD-500-42	42	56	63-1/4		61-1/2													
TULD-500-48	48	60	69-1/4		67-1/2													

HEAVY DUTY TAKE-UP (TUHD)

Figure 4.4 TUHD Drawings

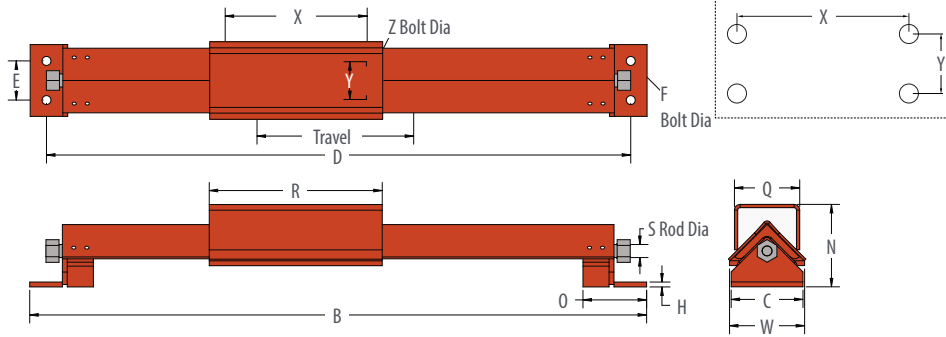

Figure 4.4-A TUHD Bearing bolt pattern EX.

Table 7.4-a TUHD BOLT Dimensions

SPECS	BEARING BRAND	
	REXNORD	REXNORD
Part Number	Rex ZEP-5215	ZAF-6307F
Bearing Size	2-5/16"	3-7/16"
Hole Pattern (2 or 4 Hole)	2 Bolt	4 Bolt
Dimension X	9-3/4"	13-1/8"
Dimension Y	-	2-3/8"
Z Bolt Diameter	3/4"	3/4"

Table 7.4 TUHD Dimensions

PART NUMBER	TRAVEL	WT (LBS)	B	C	D	E	F BOLT DIA	H	N	O	Q	R	S ROD DIA	W	X	Y	Z BOLT DIA	
TUHD-200-12	12	61	31		29													
TUHD-200-18	18	68	37		35													
TUHD-200-24	24	75	43		41													
TUHD-200-30	30	82	49		47													
TUHD-200-36	36	89	55	5	53	2-1/2	5/8	1/4	5-1/4	4	5 1/2	11	1	6-7/16	*	*	*	
TUHD-200-42	42	96	61		59													
TUHD-200-48	48	103	67		65													
TUHD-200-60	60	116	79		77													
TUHD-250-12	12	88	35-1/4		32-3/4													
TUHD-250-18	18	96	41-1/4		38-3/4													
TUHD-250-24	24	102	47-1/4		44-3/4													
TUHD-250-30	30	110	53-1/4	5-3/4	50-3/4	3	5/8	3/8	6-1/4	5	6	13-1/4	1	8-1/2	*	*	*	
TUHD-250-36	36	118	59-1/4		56-3/4													
TUHD-250-42	42	125	65-1/4		62-3/4													
TUHD-250-48	48	133	71-1/4		68-3/4													
TUHD-250-60	60	148	83-1/4		80-3/4													
TUHD-300-12	12	130	38-1/4		35-1/2													
TUHD-300-18	18	141	44-1/4		41-1/2													
TUHD-300-24	24	151	50-1/4		47-1/2													
TUHD-300-30	30	161	56-1/4	6-1/2	53-1/2	3	3/4	1/2	7	6	6	14-1/4	1-1/4	8-13/16	*	*	*	
TUHD-300-36	36	171	62-1/4		59-1/2													
TUHD-300-42	42	181	68-1/4		65-1/2													
TUHD-300-48	48	191	74-1/4		71-1/2													
TUHD-300-60	60	211	86-1/4		83-1/2													
TUHD-350-12	12	140	40		37-1/4													
TUHD-350-18	18	150	46		43-1/4													
TUHD-350-24	24	160	52		49-1/4													
TUHD-350-30	30	170	58	6-1/2	55-1/4	3	3/4	1/2	7	6	6	16	1-1/4	8-13/16	*	*	*	
TUHD-350-36	36	180	64		61-1/4													
TUHD-350-42	42	191	70		67-1/4													
TUHD-350-48	48	201	76		73-1/4													
TUHD-350-60	60	221	88		85-1/4													
TUHD-400-12	12	170	44		41-1/4													
TUHD-400-18	18	180	50		47-1/4													
TUHD-400-24	24	191	56		53-1/4													
TUHD-400-30	30	201	62	6-1/2	59-1/4	3	3/4	1/2	7	6	7	20	1-1/4	8-13/16	*	*	*	
TUHD-400-36	36	211	68		65-1/4													
TUHD-400-42	42	221	74		71-1/4													
TUHD-400-48	48	231	80		77-1/4													
TUHD-400-60	60	252	92		89-1/4													
TUHD-500-12	12	255	49-1/2		47													
TUHD-500-18	18	268	55-1/2		53													
TUHD-500-24	24	280	61-1/2		59													
TUHD-500-30	30	292	67-1/2		65													
TUHD-500-36	36	305	73-1/2		71													
TUHD-500-42	42	318	79-1/2	6-7/8	77	4	7/8	1/2	7-3/4	7	8-1/2	23-1/2	1-1/2	10-1/4	*	*	*	
TUHD-500-48	48	331	85-1/2		83													
TUHD-500-60	60	356	97-1/2		95													
TUHD-500-72	72	382	109-1/2		107													
TUHD-500-96	96	434	133-1/2		131													
TUHD-500-120	120	485	157-1/2		155													
TUHD-600-12	12	454	57-3/4		54-1/4													
TUHD-600-18	18	473	63-3/4		60-1/4													
TUHD-600-24	24	491	69-3/4		66-1/4													
TUHD-600-30	30	510	75-3/4	10	72-1/4	6	1	3/4	10	10	10	25-3/4	2	13-1/4	*	*	*	
TUHD-600-36	36	529	81-3/4		78-1/4													
TUHD-600-42	42	547	87-3/4		84-1/4													
TUHD-600-48	48	566	93-3/4		90-1/4													
TUHD-600-60	60	603	105-3/4		102-1/4													
TUHD-800-12	12	805	70-7/8		60-7/8													
TUHD-800-18	18	833	76-7/8		66-7/8													
TUHD-800-24	24	861	82-7/8		72-7/8													
TUHD-800-30	30	889	88-7/8	12	78-7/8	6	1-1/4	3/4	12-5/8	11-7/16	12	36	2-1/2	13-13/16	*	*	*	
TUHD-800-36	36	917	94-7/8		84-7/8													
TUHD-800-42	42	944	100-7/8		90-7/8													
TUHD-800-48	48	972	106-7/8		96-7/8													
TUHD-800-60	60	1,028	118-7/8		108-7/8													

*Consult Superior with bearing specifications, bearing holes can be drilled to order.

TOP ANGLE TAKE-UP (TUTA)

Figure 4.5 TUTA Drawings

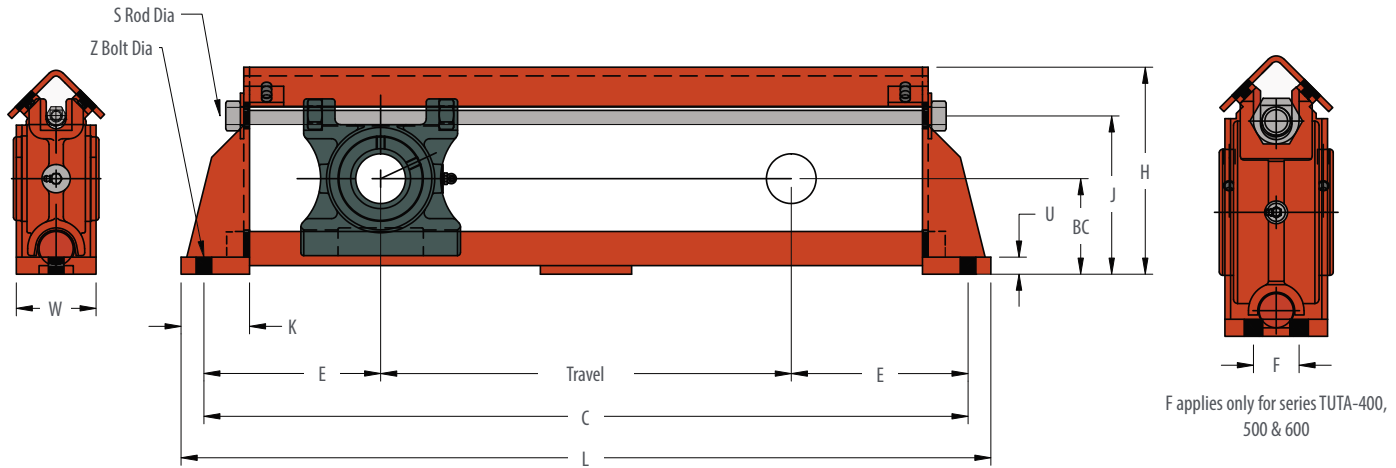

Table 7.5 TUTA Dimensions

PART NUMBER	TRAVEL	WT (LBS)	BC	C	E	F	H	J	K	L	S ROD DIA	U	W	Z BOLT DIA
TUTA-100-12	12	31		26-1/2						28-1/2	3/4	3/4	3-1/2	
TUTA-100-18	18	37	3-15/16	32-1/2	7-1/4	N/A	8-3/8	6-5/16	3	34-1/2				5/8
TUTA-100-24	24	43		38-1/2						40-1/2				
TUTA-200-12	12	37		27-1/2						29-1/2	3/4	3/4	3-1/2	
TUTA-200-18	18	43	4-3/16	33-1/2	7-3/4	N/A	8-15/16	6-15/16	3	35-1/2				5/8
TUTA-200-24	24	49		39-1/2						41-1/2				
TUTA-300-12	12	37		28-1/2						30-1/2				
TUTA-300-18	18	44		34-1/2						36-1/2				
TUTA-300-24	24	50		40-1/2						42-1/2				
TUTA-300-30	30	57	4-3/8	46-1/2	8-1/4	N/A	9-7/8	7-3/8	3-1/2	48-1/2	1	3/4	4	3/4
TUTA-300-36	36	64		52-1/2						54-1/2				
TUTA-300-42	42	71		58-1/2						60-1/2				
TUTA-300-48	48	77		64-1/2						66-1/2				
TUTA-400-12	12	36		30-1/2						32-1/2				
TUTA-400-18	18	43		36-1/2						38-1/2				
TUTA-400-24	24	51		42-1/2						44-1/2				
TUTA-400-30	30	58	4-15/16	48-1/2	9-1/4	2	10-7/8	8-5/16	3-1/2	50-1/2	1	3/4	4-1/2	5/8
TUTA-400-36	36	65		54-1/2						56-1/2				
TUTA-400-42	42	72		60-1/2						62-1/2				
TUTA-400-48	48	79		66-1/2						68-1/2				
TUTA-500-12	12	42		32						34-1/2				
TUTA-500-18	18	50		38						40-1/2				
TUTA-500-24	24	58		44						46-1/2				
TUTA-500-30	30	66	5-7/16	50	10	2	12-5/16	9-7/16	4	52-1/2	1-1/4	3/4	4-1/2	3/4
TUTA-500-36	36	74		56						58-1/2				
TUTA-500-42	42	82		62						64-1/2				
TUTA-500-48	48	90		68						70-1/2				
TUTA-600-12	12	57		36						38-1/2				
TUTA-600-18	18	67		42						44-1/2				
TUTA-600-24	24	77		48						50-1/2				
TUTA-600-30	30	87	7	54	12	2-1/2	14-1/8	11-3/8	4-1/2	56-1/2	1-1/4	3/4	5-1/2	3/4
TUTA-600-36	36	97		60						62-1/2				
TUTA-600-42	42	107		66						68-1/2				
TUTA-600-48	48	117		72						74-1/2				

CENTER PULL TAKE-UP (TUCP)

Figure 4.6 TUCP Drawings

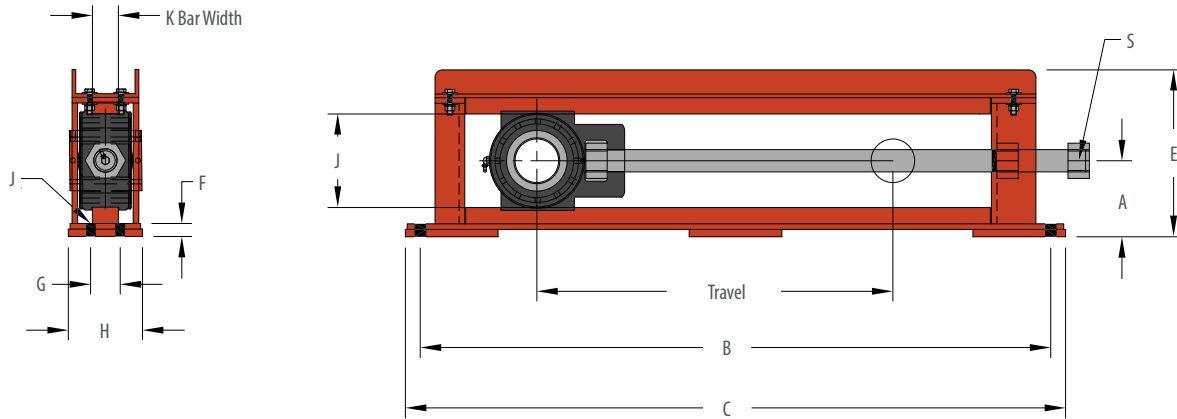

Table 7.6 TUCP Dimensions

PART NUMBER	TRAVEL	WT (LBS)	A	B	C	E	F	H	G	J	K	S ROD DIA	Z BOLT DIA
TUCP-308-12	12	33		26	28								
TUCP-308-18	18	37		32	34								
TUCP-308-24	24	42	3-7/16	38	40	7	11/16	3	N/A	3-5/8	1/2	3/4	1/2
TUCP-308-30	30	47		44	46								
TUCP-308-36	36	52		50	52								
TUCP-400-12	12	46		27-1/2	29-1/2								
TUCP-400-18	18	61		33-1/2	35-1/2								
TUCP-400-24	24	69	3-15/16	39-1/2	41-1/2	8-5/8	13/16	4	N/A	4-1/8	5/8	1	5/8
TUCP-400-30	30	77		45-1/2	47-1/2								
TUCP-400-36	36	85		51-1/2	53-1/2								
TUCP-408-12	12	55		27-1/2	29-1/2								
TUCP-408-18	18	64		33-1/2	35-1/2								
TUCP-408-24	24	72	4-7/16	39-1/2	41-1/2	9-1/4	11/16	4	N/A	4-5/8	3/4	1-1/8	5/8
TUCP-408-30	30	80		45-1/2	47-1/2								
TUCP-408-36	36	88		51-1/2	53-1/2								
TUCP-502-12	12	64		28-1/2	30-1/2								
TUCP-502-18	18	74		34-1/2	36-1/2								
TUCP-502-24	24	84	4-3/8	40-1/2	42-1/2	9-1/2	13/16	4	N/A	5-1/4	1	1-1/4	3/4
TUCP-502-30	30	94		46-1/2	48-1/2								
TUCP-502-36	36	104		52-1/2	54-1/2								
TUCP-515-12	12	103		30-1/2	32-1/2								
TUCP-515-18	18	119		36-1/2	38-1/2								
TUCP-515-24	24	136	5-1/8	42-1/2	44-1/2	11-5/32	7/8	5	2	6	1-3/4	1-1/2	5/8
TUCP-515-30	30	152		48-1/2	50-1/2								
TUCP-515-36	36	169		54-1/2	56-1/2								
TUCP-613-12	12	121		32	34-1/4								
TUCP-613-18	18	140		38	40-1/4								
TUCP-613-24	24	159	5-11/16	44	46-1/4	12-1/16	1	5	2	6-7/8	1-3/4	1-3/4	3/4
TUCP-613-30	30	177		50	52-1/4								
TUCP-613-36	36	196		56	58-1/4								
TUCP-810-12	12	180		36	38-1/2								
TUCP-810-18	18	202		42	44-1/2								
TUCP-810-24	24	224	7	48	50-1/2	14-3/4	1-3/16	6	2-1/2	8-3/4	2	2	3/4
TUCP-810-30	30	246		54	56-1/2								
TUCP-810-36	36	268		60	62-1/2								
TUCP-908-12	12	290		40-3/4	45-3/4								
TUCP-908-18	18	320		46-3/4	51-3/4								
TUCP-908-24	24	351	7-1/2	52-3/4	57-3/4	16-1/16	1-1/4	9	5	9-5/8	2	2	1-1/8
TUCP-908-30	30	381		58-3/4	63-3/4								
TUCP-908-36	36	412		64-3/4	69-3/4								
TUCP-908-42	42	442		70-3/4	75-3/4								
TUCP-1004-12	12	398		44-1/2	49-1/2								
TUCP-1004-18	18	436		50-1/2	55-1/2								
TUCP-1004-24	24	473	8-1/8	56-1/2	61-1/2	17-5/16	1-1/2	10	5-1/2	10-3/8	2	2-1/4	1-1/8
TUCP-1004-30	30	511		62-1/2	67-1/2								
TUCP-1004-36	36	549		68-1/2	73-1/2								
TUCP-1004-42	42	586		74-1/2	79-1/2								

TAKE-UP INTERCHANGE & BEARING SIZES

Table 7.7 TUTA INTERCHANGE AND BEARING SIZES

TOP ANGLE TAKE-UP FRAME SIZES				BEARING SIZES (BY BEARING TYPE)			
SUPERIOR	DODGE	PPI	CCI	DODGE TYPE E TPE, LINK BELT ETPB22400	DODGE S-2000	NORMAL DUTY DODGE TYPE G* (SC)	MEDIUM DUTY DODGE TYPE GM** (SCM)
TUTA-100	TP-10	PTA200	CTA10	1-3/4" to 2"	1-15/16" to 2"	1-15/16" to 2"	1-11/16" to 1-3/4"
TUTA-200	TP-20	PTA203	CTA20	2-3/16"	-	2-3/16" to 2-1/4"	1-15/16" to 2"
TUTA-300	TP-30	PTA208	CTA30	2-1/4" to 2-1/2"	2-3/16"	2-7/16"	2-3/16" to 2-1/4"
TUTA-400	TP-40	PTA300	CTA40	2-11/16" to 3"	2-7/16" to 3"	2-15/16"	2-7/16" to 2-11/16"
TUTA-500	TP-50	PTA308	CTA50	3-3/16" to 3-1/2"	3-7/16"	-	2-15/16" to 3"
TUTA-600	TP-60	PTA400	CTA60	3-15/16" to 4"	3-15/16"	-	3-7/16" to 3-1/2"

Table 7.8 TUHD INTERCHANGE AND BEARING SIZES

HEAVY DUTY TAKE-UP FRAME SIZES						BEARING SIZES (BY BEARING TYPE)			
SUPERIOR	DODGE	PPI	CCI	LINK BELT	BROWNING	DODGE TYPE E, REX ZEP, LINK BELT EPB22400, SKF SYE	DODGE S-2000, REX ZA, LINK BELT PB22400, SKF SYR	DODGE TAF, REX ZAF, SEALMASTER USRB	DODGE USAF/SAF-XT/SAFS/ ISAF, SKF SAF22500, LINK BELT PLB6800
TUHD-200	HD-200	PHD200	CHD200	LHD20	T2000A/B/C	1-7/16" to 2-1/2"	1-7/16" to 2-1/2"	1-7/16" to 2-1/2"	1-7/16" to 2-3/16"
TUHD-250	HD-250	PHD208	CHD250	LHD25	T2000D/E	2-11/16" to 3"	2-11/16" to 3"	2-11/16" to 3"	2-7/16" to 3"
TUHD-300	HD-300	PHD300	CHD300	LHD30	T2000F/G	-	3-3/16" to 3-1/2"	-	3-3/16"
TUHD-350	HD-350	PHD308	CHD350	LHD35	T2000H/J	3-3/16" to 3-1/2"	3-15/16" to 4-1/2"	3-3/16" to 4"	3-7/16" to 3-1/2"
TUHD-400	HD-400	PHD400	CHD400	LHD40	T2000K	3-15/16" to 5"	4-15/16" to 5"	4-7/16" to 5"	3-15/16" to 4-1/2"
TUHD-500	HD-500	PHD500	CHD500	LHD50	T2000M/N	5-7/16" to 6"	-	5-7/16"	4-15/16" to 5-1/2"
TUHD-600	-	PHD600	-	-	-	6-7/16" to 7"	-	5-15/16" to 6"	5-15/16" to 6"
TUHD-800	-	PHD800	-	-	-	-	-	6-7/16" to 7"	6-7/16" to 9"

Table 7.9 TULD INTERCHANGE AND BEARING SIZES

LIGHT DUTY TAKE-UP FRAME SIZES			BEARING SIZES (BY BEARING TYPE)		
SUPERIOR	DODGE	PPI*	NORMAL DUTY - DODGE SC/SXR/DL/GT, SEAL- MASTER NP, BROWNING VPS-200	MEDIUM DUTY - DODGE SCM/DLM/GTM, SEALMASTER MP, BROWNING VPS-300	DODGE S-2000, REX ZA, LINK BELT PB22400, SKF SYR
TULD-100	LD-10	PLD/PMD100	1/2" to 1"	-	-
TULD-200	LD-20	PLD/PMD108	1-1/16" to 1-3/4"	1/2" to 1-1/2"	1-3/8" to 1-3/4"
TULD-300	LD-30	PLD/PMD200	1-15/16" to 2"	1-11/16" to 1-3/4"	1-15/16" to 2"
TULD-400	LD-40	PLD/PMD208	2-3/16" to 2-7/16"	1-15/16" to 2-1/4"	2-3/16" to 2-7/16"
TULD-450	LD-45	PLD/PMD300	2-1/2" to 2-11/16"	2-7/16" to 2-1/2"	2-11/16" to 3"
TULD-500	LD-50	PLD/PMD308	2-15/16"	2-11/16" to 3-1/2"	3-7/16"

* PLD = 2 Saddles & PMD = 1 saddle (Review height dimensions of manufacturer for exact dimensions)

Table 7.10 TUCP INTERCHANGE AND BEARING SIZES

CENTER PULL TAKE-UP FRAME SIZES						BEARING SIZES (BY BEARING TYPE)			
SUPERIOR	DODGE	PPI	CCI	REXNORD	BROWNING	DODGE TYPE E (WSTU-E), BROWNING TUE920	DODGE TYPE S-2000 (WSTU-S2), BROWNING ST1000	REX ZT2000	REX ZT5000
TUCP-308	CP308	PCP108	CCP308	ZHT-5	-	1-3/8" to 1-7/16"	1-3/8" to 1-1/2"	1-1/2"	-
TUCP-400	CP400	PCP200	CCP400	ZHT-6	T1000D	1-1/2" to 2"	1-11/16" to 2"	1-11/16" to 2"	1-1/2" to 1-15/16"
TUCP-408	CP408	PCP203	CCP408	ZHT-7	T1000EH	2-3/16"	2-3/16"	2-3/16" to 2-1/4"	2" to 2-3/16"
TUCP-502	CP502	PCP208	CCP502	ZHT-8	T1000F	2-1/4" to 2-1/2"	2-7/16"	2-3/8" to 2-1/2"	2-7/16"
TUCP-515	CP515	PCP300	CCP515	ZHT-9	T1000GH	2-11/16" to 3"	2-11/16" to 3"	2-11/16" to 3"	2-1/2" to 2-15/16"
TUCP-613	CP613	PCP308	CCP613	ZHT-10	T1000JH	3-7/16" (TUE920 only)	3-7/16"	3-3/16" to 3-1/2"	3-3/16" to 3-7/16"
TUCP-810	CP810	PCP400	CCP810	ZHT-11	T1000K	3-15/16" to 4-1/2" (TUE920)	3-15/16"	3-11/16" to 4"	3-11/16" to 4"
TUCP-908	CP908	PCP408	CCP908	ZHT-12	-	-	4-7/16"	-	4-3/16" to 4-1/2"
TUCP-1004	CP1004	PCP500	-	ZHT-13	-	-	4-15/16"	-	4-15/16" to 5"

Table 7.11 TUWS INTERCHANGE AND BEARING SIZES

WIDESLOT TAKE-UP FRAME SIZES			BEARING SIZES (BY BEARING TYPE)	
SUPERIOR	DODGE	PPI	NORMAL DUTY - DODGE SC/SXR/DL/GT, SEALMASTER ST, BROWNING VTWS-200	MEDIUM DUTY - DODGE SCM/DLM/GTM, SEALMASTER MST, BROWNING VTWS-300
TUWS-100	WS-300	PWS100	1/2" to 1"	-
TUWS-150	WS-308	PWS108	1-1/16" to 1-7/16"	1" to 1-1/4"
TUWS-200	WS-400	PWS200	1-1/2" to 2"	1-7/16" to 1-3/4"
TUWS-250	WS-502	PWS208	2" to 2-7/16"	1-15/16" to 2-1/4"
TUWS-300	WS-515	PWS300	2-1/2" to 2-15/16"	2-7/16" to 2-11/16"
TUWS-350	WS-608	PWS308	-	2-15/16" to 3"

XT BUSHING INSTALLATION

XT BUSHING INSTALLATION INSTRUCTIONS

Follow all instructions carefully to ensure satisfactory performance of both pulley and bushings. For factory installed shaft units, retighten the capscrews with a torque wrench set at the proper value shown on Table 8.1.

Prior to installation, polish the following components:

- Surface of shaft
- Bore of the bushing
- Tapered inside diameter of the XT hub
- Tapered outside diameter of the XT bushing

Remove all burrs and foreign material. Particles left on the mating surfaces may cause improper installation.

Note: DO NOT LUBRICATE MATING SURFACE

1. If pulley is to be keyed to shaft, be certain both shaft and bushing keyways are clean, smooth, and free of burrs. Check key size with both shaft and bushing keyways. Place keys into shaft keyways. Pulley bushing keyways require alignment of both shaft keyways for proper bushing to hub installation.
2. Place shaft into pulley, being certain not to damage the bore of the hubs.
3. Carefully insert a wedge in the bushing split and tap lightly to expand the bushing. USE CAUTION; EXCESSIVE EXPANSION WILL CAUSE THE BUSHING TO SPLIT. Slide bushings onto shaft and into hubs keeping the drilled holes of the bushings lined up with the threaded holes of the hub. Place the capscrews into the drilled holes of each bushing and hand-tighten cap screws into the threaded holes of the hubs. Remove the wedge.
4. Find the desired shaft position and tighten the capscrews in each bushing slightly so that the bushings are snug in the hubs.
5. Using a torque wrench and recommended torque (see Table 8.1) tighten capscrews alternately and evenly in one bushing only. Use the numbered sequence on the bush flange capscrew heads in Figure 4, starting with 1 first, 2 second, and so on, with all capscrews being tightened until the specified torque no longer turns the capscrews. DO NOT TIGHTEN BEYOND RECOMMENDED VALUES. Check to be certain the surfaces on both sides of the split are even.

WARNING: DO NOT EXCEED RECOMMENDED TORQUE IN ATTEMPT TO PULL BUSHING FLANGE FLUSH WITH HUB FACE - THERE SHOULD BE CLEARANCE WHEN TIGHTENED. If the bushing flange is pulled flush with hub face while tightening capscrews to recommended torque, check for undersized shaft.

6. Tighten the second bushing following step #5.

Figure 5.1 Numbered Capscrew Sequence

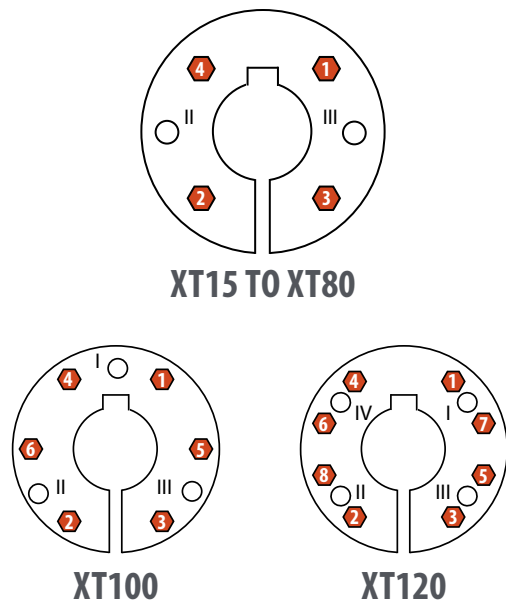

Table 8.1 Recommended XT Capscrew Torque

XT SIZE	NUMBER AND SIZE OF CAPSCREWS	SCREW TORQUE (IN.-LBS.)
XT15	(QTY 4) 1/4 – 20 NC X 1	96
XT20	(QTY 4) 5/16 – 18 NC X 1-1/4	204
XT25	(QTY 4) 3/8 – 16 NC X 1-3/4	360
XT30	(QTY 4) 7/16 – 14 NC X 1-1/2	540
XT35	(QTY 4) 1/2 – 13 NC X 1-3/4	840
XT40	(QTY 4) 9/16 – 12 NC X 2	1200
XT45	(QTY 4) 5/8 – 11 NC X 2-1/4	1680
XT50	(QTY 4) 3/4 – 10 NC X 2-1/2	3000
XT60	(QTY 4) 7/8 – 9 NC X 2-1/2	4800
XT70	(QTY 4) 1-8 NC X 3	7200
XT80	(QTY 4) 1-1/8 – 7 NC X 3-1/2	9000
XT100	(QTY 6) 1-1/8 – 7 NC X 3-1/2	9000
XT120	(QTY 8) 1-1/8 – 7 NC X 3-1/2	9000

QD BUSHING INSTALLATION

QD BUSHING INSTALLATION INSTRUCTIONS

Follow all instructions carefully to ensure satisfactory performance of both pulley and bushings. For factory installed shaft units, retighten the capscrews with a torque wrench set at the proper value shown in Table 8.2.

Prior to installation, polish the following components:

- Surface of shaft
- Bore of the bushing
- Tapered inside diameter of the QD® hub
- Tapered outside diameter of the QD® bushing

Remove all burrs and foreign material. Particles left on the mating surfaces may cause improper installation.

Note: DO NOT LUBRICATE MATING SURFACES

1. If pulley is to be keyed to shaft, be certain both the bushing keyway and the shaft keyseats are clean, smooth, and free of burrs. Check key size in both bushings and shaft keyways. Place keys into shaft keyseats. Pulley bushings require alignment of both shaft keyseats for proper bushing to hub installation.
2. Place shaft into pulley, being certain not to damage the bore of the hubs or the surface of the shaft, and locate the desired position.
3. Carefully insert a wedge in the bushing split and tap lightly to expand the bushing. USE CAUTION: EXCESSIVE EXPANSION WILL CAUSE THE BUSHING TO SPLIT. Slide bushings onto shaft and into hubs keeping the unthreaded holes of the bushings lined up with the threaded holes of the hub.
4. Place capscrews with locking washers into the unthreaded holes of each bushing and hand –tighten capscrews into the threaded holes of the hubs.
5. Remove the wedge from the bushing split.
6. Using an accurate torque wrench, tighten each capscrew per numbered sequence given in Figure 5, alternately and evenly in one bushing only, applying no more pressure than recommended in the following table. Then, using the hammer and a heavy steel or bronze bar, drift on the face of the bushing starting opposite the split. Avoid drifting outside of the bolt circle to prevent damage to the bushing. Continue drifting in clockwise and counter clockwise directions from the point opposite the split around the bushings until you reach the specified torque on all capscrews. For JS and larger bushings, repeat this procedure until the specified torque no longer turns the capscrews after drifting.
7. Tighten the other bushing by the method described in step #6. When two bushings are used, complete tightening of one bushing before proceeding to the second.
8. Do not over tighten the capscrews. The bushing should not pull tight (bottom out) against the hub. Clearance must be maintained. Surfaces on both sides of the bushing split should be even, and the gap between the hub and bushings should be uniform at all locations. If the bushing flange contacts the face of the hub, check for undersized shafting.

Figure 5.2 Numbered Capscrew Sequence

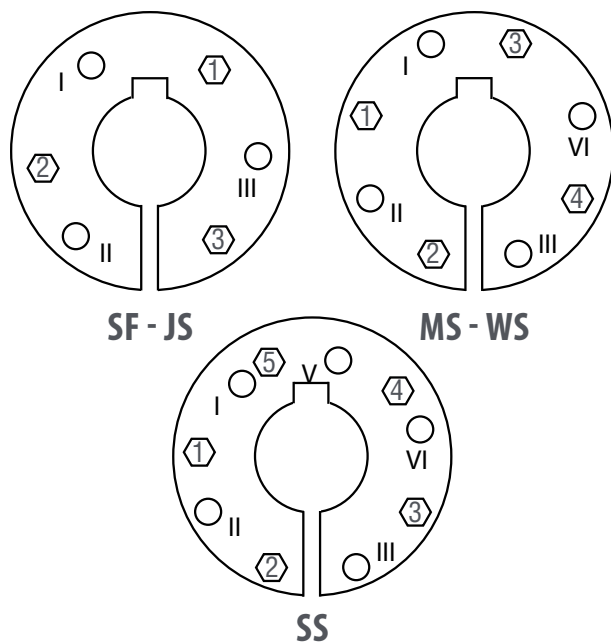

Table 8.2 Recommended QD Capscrew Torque

QD SIZE	NUMBER AND SIZE OF CAPSCREWS	SCREW TORQUE (IN-LBS.)
SDS	(QTY 3) 1/4 - 20 NC X 1-3/8	
SK	(QTY 3) 5/16 - 18 NC X 2	
SF	(QTY 3) 3/8 - 16 NC X 2	360
E	(QTY 3) 1/2 - 13 NC X 2-1/4	720
F	(QTY 3) 9/16 - 12 NC X 3-5/8	904
JS	(QTY 3) 5/8 - 11 NC X 2-1/2	1620
MS	(QTY 4) 3/4 - 10 NC X 3	2700
NS	(QTY 4) 7/8 - 9 NC X 3-1/2	3600
PS	(QTY 4) 1-8 - NC X 4-1/2	5400
WS	(QTY 4) 1-1/8 - 7 NC X 5	7200
SS	(QTY 5) 1-1/8 - 7 NC X 5	9000

BUSHING MAINTENANCE & REMOVAL

XT BUSHING MAINTENANCE AND BUSHING REMOVAL

Maintenance: before start up and once a week for the first month of operation, inspect the bushings and check the torque setting. After the first month of operation repeat inspection at periodic maintenance intervals.

Removal:

1. Remove all capscrews.
2. Insert capscrews into all threaded removal holes on bushings.
3. Tighten the capscrews alternately and evenly in one bushing only. Use the numbered sequence near the threaded removal holes in Figure 4, starting with 1 first, 2 second, etc., with all threaded holes being used until the bushing is loosened in the hub. If the bushing does not loosen immediately, tap on the bushing with a rubber mallet.
4. Remove the bushing from the shaft.
5. Remove the second bushing following steps 1-4.

QD BUSHING MAINTENANCE AND BUSHING REMOVAL

Maintenance: before start up and once a week for the first month of operation, inspect the bushings and check the torque setting. After the first month of operation repeat inspection at periodic maintenance intervals.

Removal:

1. Clean the exposed shaft ends.
2. Remove all capscrews.
3. Insert the capscrews into all threaded jacking screw holes in the bushing flange.
4. Turn the capscrews against the flange of the hub alternately and evenly in one bushing. A few turns on each screw should release the grip of the bushing on the shaft. Do not apply excessive torque on the jacking holes to the bushing split. If the bushing does not break loose, tap the bushing with a rubber mallet.
5. Remove the bushing from the shaft. If necessary, carefully insert a wedge in the bushing split to expand the bushing bore.
6. Repeat steps 1 through 5 for the other bushing.

PULLEY STRESS CONTRIBUTORS

VARIABLES

End disk bellows and bushing expansion are dependent on:

- Bushing/hub taper
- Manufacturing of hub/bushing system
- Bushing/hub installation alignment
- Assembler bolt torque
- Friction along shaft
- Friction along tapered surfaces
- Friction along threaded surfaces of bolts and holes

BELT TENSION

DRIVE WEIGHT

SELF WEIGHT

The highest contributors to stress have the highest variability, therefore highest risk to pulley reliability!

PULLEY STRESS ANALYSIS DIAGRAMS

The following diagrams indicate location of stress by each contributing source

SELF WEIGHT

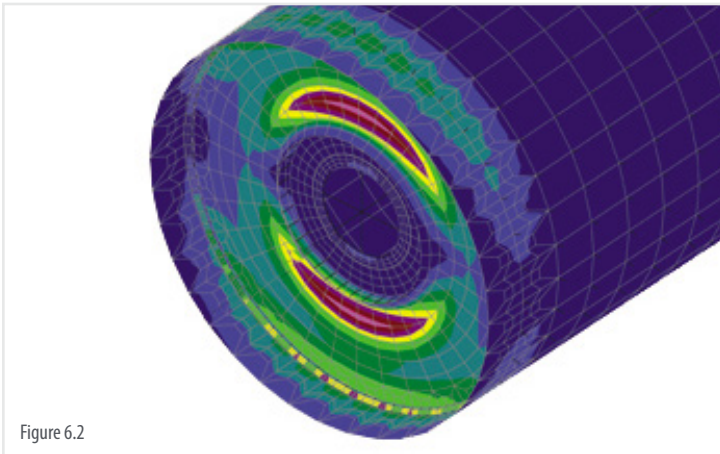

DRIVE WEIGHT

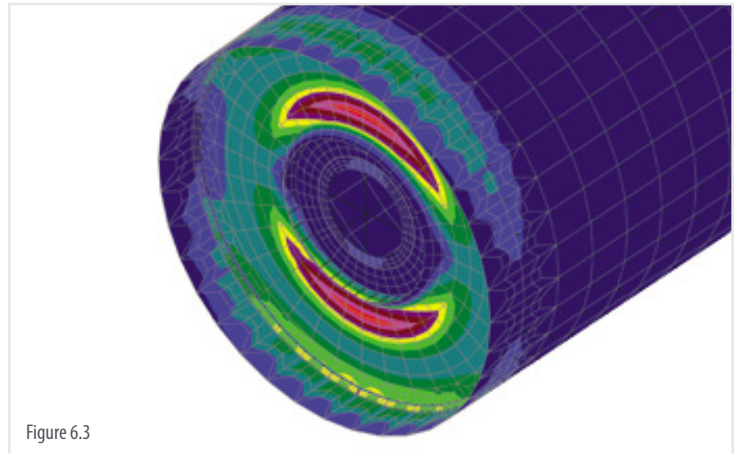

BELT TENSION

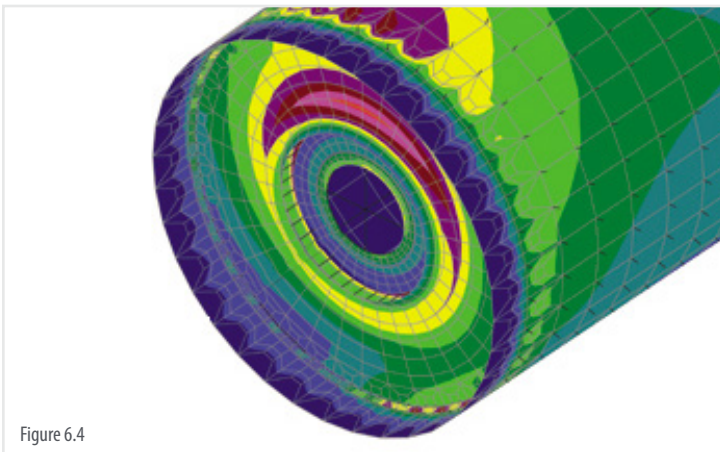

BUSHING EXPANSION AND END DISK BELLOWS

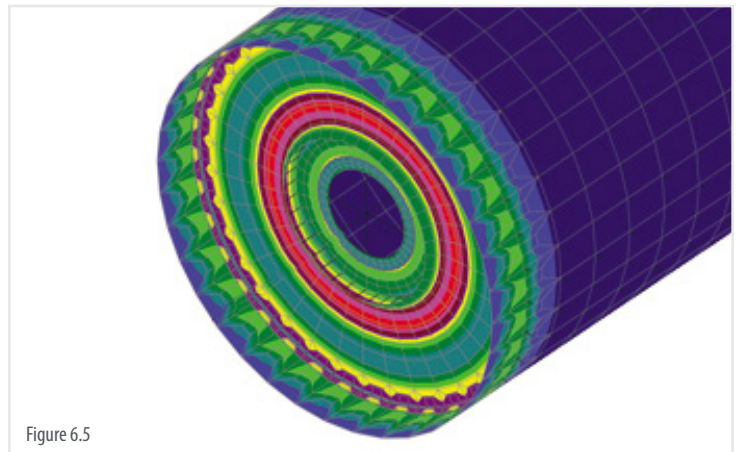

SHAFT WEIGHTS & ORDERING INFORMATION

Table 9.1

SHAFT LENGTH	WEIGHTS											
	SHAFT DIAMETER (INCHES)											
	1 3/16	1 7/16	1 11/16	2 3/16	2 7/16	2 15/16	3 7/16	3 15/16	4 7/16	4 15/16	5 7/16	5 15/16
1' 6"	5	6	13	17	23	36	48	64	79	100	117	143
2' 0"	9	10	19	28	30	44	64	81	104	129	161	186
2' 6"	11	13	26	30	43	60	80	107	133	165	195	237
3' 0"	12	18	31	36	45	66	95	124	158	195	237	282
3' 6"	15	21	34	47	54	82	110	145	184	228	276	329
4' 0"	17	25	39	50	63	94	126	166	210	260	316	377
4' 6"	18	27	43	59	69	106	142	186	237	293	355	424
5' 0"	21	30	49	62	77	113	158	207	263	326	395	471
5' 6"	24	32	54	68	84	125	173	228	289	358	434	518
6' 0"	25	35	61	75	96	139	189	248	315	391	474	565
6' 6"	27	37	64	81	105	152	205	269	342	423	513	612
7' 0"	29	40	69	90	110	163	221	290	368	456	553	659
7' 6"	30	42	77	99	118	175	237	311	394	488	592	706
8' 0"	32	47	83	103	125	186	252	331	420	521	632	753
8' 6"	35	48	88	107	134	197	268	352	447	553	671	800
9' 0"	36	53	93	116	141	205	284	373	473	586	711	847
9' 6"	39	55	96	119	153	220	300	393	500	618	750	894
10' 0"	41	57	101	125	160	228	315	414	526	651	790	941

ORDERING SHAFTING

When ordering shafting, specify the following:

- Diameter and Length
- Number and size of key ways required
- Length of shaft that extends beyond each end of the pulley
- Diameter and length of journal, if required
- Bearing centers

To order shafting, please copy and complete the sketch on page 11.

*Refer to page 11

SHAFT FORMULAS

Shaft Deflection Formula

$$\tan \delta = \frac{RA(B-2A)}{4Eyl}$$

Where:

A = Moment arm for the pulley (inches)

B = Bearing centers (inches)

R = Resultant pulley load (pounds)

Ey = Young's modulus in PSI (29 x 10⁶ for steel)

I = Area moment of inertia of shaft in inches⁴ (.049087 d⁴)

D = Diameter of shaft

tan δ = Tangent of the angle made by the deflected shaft and its neutral axis before bending at the pulley hub.

Allowable Slope:

tan δ = .0023 inches per inch or tan of 8 minutes. If the slope is greater than .0023 it will be necessary to go to a larger shaft diameter or consult your manufacturer.

NOTE: THE RESULTANT DEFLECTION CALCULATED USING THESE FORMULAS WILL EXCEED THE ACTUAL DEFLECTION WHICH WILL DEPEND ON THE PULLEY CONSTRAINT.

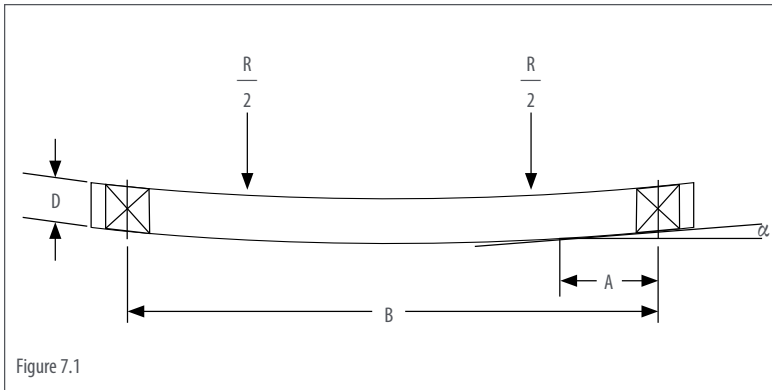

Figure 7.1

Shaft Stress Formula

$$D = \sqrt[3]{\frac{32FS}{\pi} \sqrt{\left(\frac{M}{Sf}\right)^2 + \frac{3}{4} \left(\frac{T}{Sy}\right)^2}}$$

For pulley and shaft applications within the scope of standard B105.1, the recommended values are:

F.S. = Factor of Safety = 1.5

Sf = Corrected shaft fatigue limit = k_a k_b k_c k_d k_e k_f k_g • Sf*

Where:

k_a = surface factor = 0.8 for machined shaft

k_b = size factor = (D)^{-0.19}

k_c = reliability factor = 0.897

k_d = temperature factor = 1.0 for -70° F to +400° F

k_e = duty cycle factor = 1.0 provided cyclic stresses do not exceed Sf*

k_f = fatigue stress concentration factor =

*Refer to page 11

STEEL	PROFILED KEYWAY	SLED RUNNER KEYWAY
Annealed (less than 200 BNH)	0.63	0.77
Quenched & Drawn (over 200 BNH)	0.50	0.63

kg = miscellaneous factor = 1.0 for normal conveyor service

Sf* = 29,000 psi for C1018

— 41,000 psi for C1045

— 47,500 psi for C4140 (annealed)

(Sf* = 0.5 tabulated ultimate tensile strength)

Sy = Yield strength = 32,000 psi for C1018

45,000 psi for C1045

60,500 psi for C140 (annealed)

M = Bending moment (inch-pounds) = RxA

2

T = Torsional moment (pound-inches)

= Te x r: where r = pulley radius

LAGGING WEIGHTS

WEIGHT INFORMATION – VULCANIZED RUBBER LAGGING WEIGHTS

Table 10.1 Crowned Drum

DIA.	LAGGING THICKNESS	WEIGHTS / FACE WIDTH (INCHES)										
		10	12	14	16	18	20	22	24	26	30	32
6"	1/4	3	3	4	4	5	6	7	7	8	10	10
	3/8	4	5	6	7	7	8	9	10	11	13	14
	1/2	5	6	8	9	10	11	12	14	15	17	19
8"	1/4	4	4	5	6	7	8	9	10	11	13	14
	3/8	5	6	7	9	10	11	12	14	15	18	19
	1/2	7	8	10	11	13	14	16	18	19	23	25
10"	1/4	4	5	6	7	8	10	11	12	13	16	17
	3/8	6	8	9	11	12	14	15	17	18	22	23
	1/2	8	10	12	14	16	18	20	22	24	28	30
12"	1/4	5	6	8	9	10	11	13	14	16	19	20
	3/8	8	9	11	13	14	16	18	20	22	26	28
	1/2	10	12	14	17	19	21	26	26	28	33	36
14"	1/4	6	7	9	10	12	13	15	16	18	22	23
	3/8	9	11	13	15	17	19	21	23	25	30	32
	1/2	12	14	17	19	22	25	27	30	33	39	42
16"	1/4	7	8	10	12	13	15	17	19	21	25	27
	3/8	10	12	14	17	19	21	24	26	29	34	37
	1/2	13	16	19	22	25	28	31	34	37	44	47
18"	1/4	8	9	11	13	15	17	19	21	23	28	30
	3/8	11	14	16	19	21	24	27	30	33	38	44
	1/2	15	18	21	25	28	31	35	38	42	49	53
20"	1/4	9	10	12	15	17	19	21	23	26	31	33
	3/8	13	15	18	21	24	27	30	33	36	43	46
	1/2	17	20	24	27	31	35	39	43	46	55	59
24"	1/4	10	13	15	17	20	22	25	28	31	37	40
	3/8	15	18	22	25	28	32	36	40	43	51	55
	1/2	20	24	29	33	37	42	46	51	56	65	70
30"	1/4	13	16	19	22	25	28	31	35	38	46	50
	3/8	19	23	27	31	35	40	44	49	54	63	68
	1/2	25	30	35	41	46	52	57	63	69	81	87
36"	1/4	15	19	22	26	28	34	38	42	46	55	59
	3/8	22	27	32	37	42	48	53	59	64	76	82
	1/2	29	36	42	49	55	62	69	76	83	97	105

DIA.	LAGGING THICKNESS	WEIGHTS / FACE WIDTH (INCHES)										
		36	38	40	44	46	51	54	57	60	63	66
6"	1/4	12	13	14	16	17	19	21	22	24	26	27
	3/8	17	18	19	21	23	26	28	30	32	34	36
	1/2	22	23	24	27	29	33	35	38	40	43	45
8"	1/4	16	17	18	21	22	25	27	29	31	34	36
	3/8	22	23	25	28	30	34	36	39	42	44	47
	1/2	28	30	32	36	38	43	46	49	52	55	59
10"	1/4	20	21	22	25	27	31	34	36	39	42	44
	3/8	27	29	31	35	37	42	45	48	51	55	58
	1/2	35	37	39	44	46	52	56	60	64	68	72
12"	1/4	23	25	27	30	32	37	40	43	46	50	53
	3/8	32	34	37	41	44	50	53	57	61	65	69
	1/2	41	44	47	52	55	62	67	72	76	81	86
14"	1/4	27	29	31	35	37	43	46	50	54	58	61
	3/8	37	40	42	48	50	57	62	66	71	76	80
	1/2	48	51	54	60	64	72	77	83	88	94	100
16"	1/4	31	33	35	40	43	49	53	57	61	66	70
	3/8	43	45	48	54	57	65	70	75	81	86	91
	1/2	54	58	61	69	73	82	88	94	100	107	113
18"	1/4	35	37	40	45	48	55	59	64	69	73	78
	3/8	48	51	54	61	64	73	79	85	90	96	102
	1/2	61	65	69	77	81	92	99	105	112	119	127
20"	1/4	39	41	44	50	53	61	66	71	76	81	87
	3/8	53	56	60	68	71	81	87	94	100	107	113
	1/2	67	72	76	85	90	102	110	117	124	132	140
24"	1/4	46	49	53	60	63	73	79	85	91	97	104
	3/8	63	67	72	81	85	97	104	112	120	128	136
	1/2	80	86	91	102	107	122	130	140	149	158	167
30"	1/4	57	62	66	75	79	91	98	106	113	121	130
	3/8	79	84	90	101	106	121	130	140	149	159	169
	1/2	100	107	113	127	134	151	162	174	185	196	208
36"	1/4	69	74	79	89	95	109	118	127	136	145	155
	3/8	94	101	107	120	127	145	156	167	178	190	202
	1/2	118	128	135	152	160	181	194	207	221	235	249

If grooved pulley (for 3/8" or 1/2" thickness) - take weight in chart and [Multiply by 0.95]

CONVEYOR DESIGN INFORMATION

Table 11.1 Characteristics of Common Bulk Materials

MATERIAL	WEIGHT (LB/FT ³)	SURCHARGE ANGLE IN °	MAX. CONVEYING ANGLE IN °
Ashes, Coal, Dry, - 3"	35-40	25-30	22
Cement, Portland	90-100	25	20
Cement, Clinker	75-80	20	18
Coal, Arthracite, Sized, 3/8"- 6"	55	12	16
Coal, Bitum., Slack	50	22	22
Coal, Bitum., ROM	50	20	18
Coke, Loose	25-30	15	20
Earth, Common, Loam, Dry	70-80	15-30	20
Earth, Clay, Dry	100-120	10-30	20
Earth, Moist	80-100	30	22
Gravel, Average, Blended	90-100	15-20	18
Gravel, Sharp	90-100	25	20
Gravel, Rounded	90-100	15	15
Iron Ore	135	20	22
Limestone, Crushed	85-90	25-30	20
Phosphate Rock	75-85	25	20
Salt, Coarse, Dry	40-45	10	20
Salt, Fine, Dry	70-80	15	22
Sand, Bank, Damp	110-120	20-30	22
Sand, Bank, Dry	90-110	10-20	15
Sand, Foundry, Shakeout	90	25	20
Sand, Silica, Dry	90-100	10-20	15
Sand, Saturated	110-130	0-15	15
Shale, Crushed	85-90	25	20
Slag, Furnace, Crushed	85-90	12	18
Slate, Crushed, - 1/2"	80-90	15	20
Soda Ash, Light	25-35	22	20
Soda Ash, Heavy	55-65	17	20
Sulphur, Crushed, - 1/2"	50-65	20	20
Sulphur, Lumpy, - 3"	80-85	25	20
Wheat	45-48	8-15	16
Wood Chips	15-25	30	25

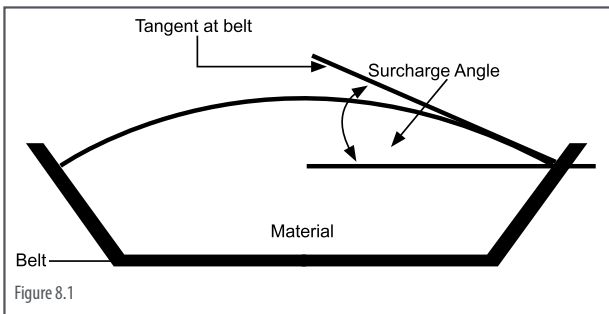

(1) All capacities shown are for material weighing 100 lbs. per cu. ft. and moving on belt 100fpm. For other weights, capacity equals table capacity.

$$\frac{\text{Wt./Cu. Ft.}}{100}$$

For other belt speeds, capacity equals table capacity (or calculated capacity).

$$\frac{\text{fpm}}{100}$$

(2) The surcharge angle is the angle formed between a horizontal line and a tangent to the material slope, both of which pass through the point where the slope meets the belt. Usually the surcharge angle is 10°-15° less than the angle of repose.

(3) "Mixed with 50% fines" means at least half of the material must be less than one half the maximum material size.

Table 11.2 Max Recommended Belt Speeds

MATERIAL BEING CONVEYED	BELT SPEEDS (FPM)	BELT WIDTH (INCHES)
Grain or other free-flowing, nonabrasive material	400	18
	600	24-30
	800	36-42
	1000	48-96
Coal, damp clay, soft ores, overburden and earth, fine-crushed stone	600	18
	800	24-36
	1000	42-60
	1200	72-96
	Heavy, hard, sharp-edged ore, coarse-crushed stone	400
600		24-36
800		Over 36
Foundry sand, prepared or damp; shakeout sand with small cores, with or without small castings (not hot enough to harm belting)	350	Any Width
Prepared foundry sand and similar damp (or dry abrasive) materials discharged from belt by rubber-edged plows	200	Any Width
Nonabrasive materials discharged from belt by means of plows -except wood pulp, where 300 to 400 preferable	200	Any Width
Feeder belts, flat or troughed, for feeding fine, nonabrasive, or mildly abrasive materials from hoppers and bins.	50 to 100	Any Width

Table 11.3 Suggested Spacing of Troughing Idlers

BELT WIDTH (INCHES)	WEIGHT OF MATERIAL HANDLED (LB/FT ³)						RETURN IDLERS
	30	50	75	100	150	200	
18	5.5	5.0	5.0	5.0	4.5	4.5	10.0
24	5.0	4.5	4.5	4.0	4.0	4.0	10.0
30	5.0	4.5	4.5	4.0	4.0	4.0	10.0
36	5.0	4.5	4.0	4.0	3.5	3.5	10.0
42	4.5	4.5	4.0	3.5	3.0	3.0	10.0
48	4.5	4.0	4.0	3.5	3.0	3.0	10.0
54	4.5	4.0	3.5	3.5	3.0	3.0	10.0
60	4.0	4.0	3.5	3.0	3.0	3.0	10.0
72	4.0	3.5	3.5	3.0	2.5	2.5	8.0
84	3.5	3.5	3.0	2.5	2.5	2.0	8.0
96	3.5	3.5	3.0	2.5	2.0	2.0	8.0

Table 11.4 Maximum Belt Capacities

BELT WIDTH (IN.)	TROUGH ANGLE	MAX. BELT CAPACITY (TPH) SURCHARGE ANGLE					MAX. MATERIAL (INCHES) FOR 20° SURCHARGE	
		5°	10°	20°	25°	30°	All Lumps Uniform Size	Mixed 10% Lumps 90% fines
18	20°	-	-	50	56	63	4	4
	35°						Not Recommended	
	45°						Not Recommended	
24	20°	-	-	96	108	120	5	7
	35°	-	102	122	132	142	5	7
	45°	106	115	132	140	170	5	7
30	20°	-	-	157	175	195	6	10
	35°	-	167	200	215	232	6	10
	45°	175	187	215	230	244	6	10
36	20°	-	-	230	260	290	7	12
	35°	-	248	295	318	343	7	12
	45°	258	278	318	340	360	7	12
42	20°	-	-	320	360	400	8	14
	35°	-	344	408	442	475	8	14
	45°	358	386	440	470	500	8	14
48	20°	-	-	430	480	530	10	16
	35°	-	457	540	645	630	10	16
	45°	475	510	584	623	660	10	16

CONVEYOR DESIGN INFORMATION

VOLUMES OF CONICAL AND CIRCULAR SHAPED STOCKPILES

Figure 9.1

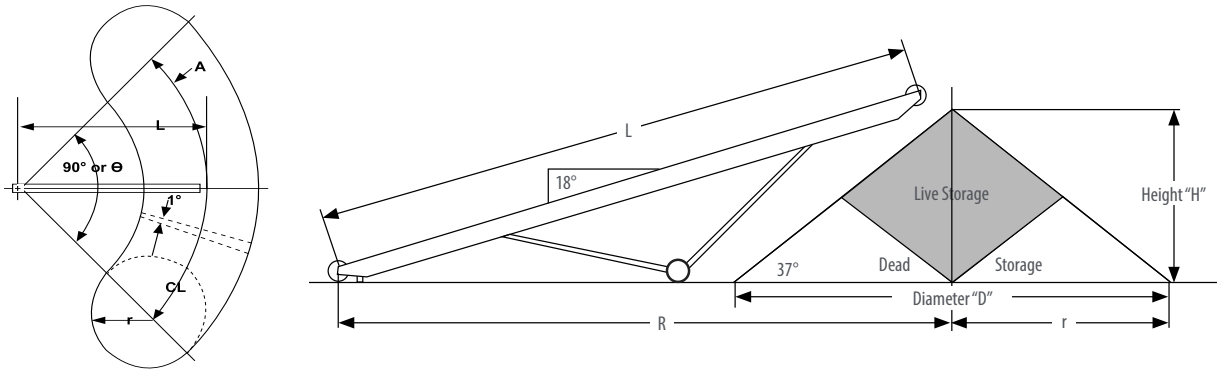

Table 11.5

DIMENSIONS IN FEET				CONICAL PILE VOLUME		VOLUME FOR ONE DEGREE ARC		90° STOCKPILE VOLUME	
L	R	H	r	C.Y.	Tons	C.Y.	Tons	C.Y.	Tons
40	39	14	19	196	265	6.5	8.8	781	1,057
50	48.5	17.5	23	359	485	12.8	17.3	1,511	2,042
60	58	20.5	27	580	783	21	28.4	2,470	3,339
70	67.5	24.5	32.5	1,004	1,355	35	47	4,154	5,585
80	77	27.5	36.5	1,421	1,918	50.2	67.8	5,939	8,020
90	87.5	30	40	1,872	2,527	68	91.6	1,992	10,771
100	96.5	32.5	43	2,331	3,145	87.8	118.6	10,233	13,819
110	105.5	35.5	47	2,058	4,128	114.6	154.7	13,372	18,051
120	115.5	38.5	51	3,884	5,243	147.6	199.2	17,168	23,171
130	125	41.5	55	4,896	6,610	185.6	250.5	21,600	29,155
140	134.5	44.5	59	6,041	8,156	229.6	310	26,705	36,056
150	144	47.5	63	7,312	9,871	280	378	32,512	43,891
170	162	54	72	10,670	14,400	400	540	46,820	63,210
190	181	60	80	14,800	20,000	560	760	65,000	87,800

Calculated volumes are in cubic yards.

Tons are based on 100 lbs. per. Cu. Ft. material, conveyor incline 18 stockpile angle of repose 37. Live storage at center of pile is theoretically 25% of the total volume.

1. Volume of conical pile = V_1

Where radius of pile (r) and height of pile (H) are known: $V_1 = r^2 H (.039)$

Where height of pile (H) and slant length of side of pile (s) are known: $V_1 = H (S^2 - H^2) (.039)$

Where slant length of side of pile (s) and angle of repose θ are known: $V_1 = S_3 (\cos \theta)^2 \sqrt{1 - (\cos \theta)^2} (.039)$

Where height of pile (H) and angle of repose (θ) are known: $V_1 = H^3 (.039)$

2. Volume of a 1° arc segment of stockpile = $V_2 = \frac{H^2 R}{\tan(\theta)^2}$

a. Where height of pile (H), distance between center line of pile and center line of conveyor pivot (R) are known, and angle of repose θ is

equal to 37° $V_2 = H^2 R$

b. For other angles of repose $V_2 = \frac{1,160}{\tan(\theta)^2} H^2 R$

3. Degrees of arc of stockpile with known arc lengths = $\frac{(1547)(\tan \theta)}{D}$ Where diameter of stockpile (D) and arc length (A) are known: $= \frac{(114.6) A}{D}$

CONVEYOR DESIGN INFORMATION

LIFT (FT) BASED ON ACTUAL PULLEY CENTER TO CENTER DISTANCE

Figure 10.1

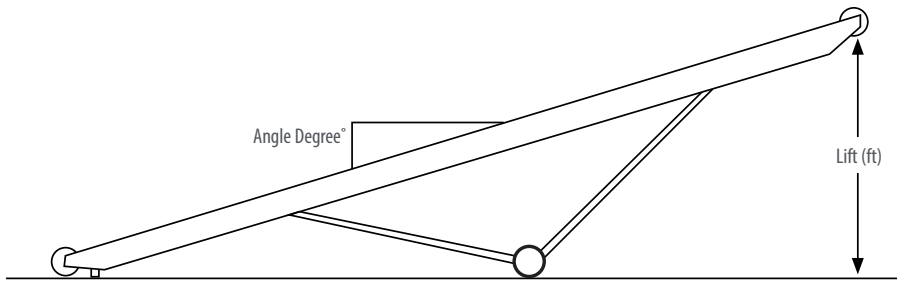

Table 11.6

ANGLE DEGREES	LENGTH OF CONVEYOR (FT)														LIFT (ft)
	10	20	30	40	50	60	70	80	90	100	120	140	160	180	
2					2	2	2	3	3	4	4	5	6	6	
4			2	3	4	4	5	6	6	7	8	10	12	13	
6		2	3	4	5	6	7	8	9	11	13	15	17	19	
8		3	4	5	7	8	9	10	12	14	17	19	22	25	
10	2	3	5	7	9	10	12	14	16	17	21	24	28	31	
12	2	4	6	8	10	12	15	17	19	21	25	29	33	37	
14	2	5	7	10	12	15	17	19	22	24	29	34	39	44	
16	3	6	8	11	14	17	19	22	25	28	33	39	44	50	
18	3	6	9	12	15	19	22	25	28	31	37	43	49	56	
20	3	7	10	14	17	21	24	27	31	34	41	48	55	62	
22	4	7	11	15	19	22	26	30	34	37	45	52	60	67	
24	4	8	12	16	20	24	28	33	37	41	49	57	65	73	

ANGLE DEGREES	LENGTH OF CONVEYOR (FT)														LIFT (ft)
	200	225	250	275	300	350	400	450	500	600	700	800	900	1000	
2	7	8	9	10	11	12	14	16	18	21	25	28	32	35	
4	14	16	18	19	21	25	28	32	35	42	49	56	63	70	
6	21	24	26	29	32	37	42	47	53	63	74	84	95	105	
8	28	31	35	38	42	49	56	63	70	83	97	111	125	139	
10	35	39	43	48	52	61	70	78	87	104	121	139	157	174	
12	42	47	52	57	62	73	83	94	104	125	146	166	187	208	
14	48	54	61	67	73	85	97	109	121	145	169	194	218	-	
16	55	62	69	76	83	97	110	124	138	166	193	221	-	-	
18	62	69	77	85	93	108	124	139	155	185	216	-	-	-	
20	68	77	86	94	103	120	137	154	171	205	-	-	-	-	
22	75	84	94	103	113	131	150	169	188	225	-	-	-	-	
24	81	92	102	122	142	142	163	183	203	-	-	-	-	-	

Hard time understanding this chart? Take the angle degrees on the left-hand side and line it up with the length of conveyor on top to get your lift in feet measurement.

CONVEYOR DESIGN INFORMATION

CONVEYOR HORSEPOWER

The sum of factors X + Y + Z (from tables below) = total horsepower at headshaft. A 10% increase in total horsepower is required for friction loss. If Z factors exceeds ½ the sum of X + Y factors, a backstop is usually necessary. Factor Z is not required for horizontal conveyors.

FACTOR X - HP REQUIRED AT HEADSHAFT FOR EMPTY CONVEYOR @ 100 FPM

Table 11.7

BELT WIDTH	CENTER TO CENTER LENGTH IN FEET															
	25	50	75	100	150	200	250	300	350	400	450	500	550	600	650	700
18"	0.2	0.3	0.3	0.3	0.4	0.4	0.45	0.5	0.55	0.6	0.65	0.7	0.8	0.9	0.95	1
24"	0.3	0.3	0.35	0.4	0.6	0.6	0.68	0.7	0.78	0.8	0.9	1	1.08	1.1	1.2	1.3
30"	0.4	0.5	0.55	0.6	0.8	0.8	0.9	1	1.1	1.2	1.3	1.4	1.6	1.7	1.8	1.9
36"	0.5	0.6	0.7	0.8	1	1	1.2	1.3	1.4	1.5	1.7	1.8	1.9	2	2.1	2.2
42"	0.7	0.8	0.83	0.9	1.1	1.3	1.5	1.5	1.8	1.9	2.1	2.2	2.4	2.5	2.7	2.8
48"	0.8	0.9	1	1.1	1.3	1.5	1.7	1.7	2	2.2	2.4	2.6	2.8	2.9	3.1	3.3

FACTORY Y - HP REQUIRED TO MOVE MATERIAL AT ANY SPEED HORIZONTALLY

Table 11.8

TPH	CENTER TO CENTER LENGTH IN FEET															
	25	50	75	100	150	200	250	300	350	400	450	500	550	600	650	700
50	0.25	0.3	0.32	0.35	0.4	0.45	0.5	0.6	0.65	0.7	0.75	0.8	0.85	0.9	0.95	1
100	0.5	0.6	0.65	0.7	0.8	0.9	1	1.1	1.2	1.3	1.5	1.6	1.7	1.8	1.9	2
150	0.75	0.8	0.9	1	1.2	1.3	1.5	1.7	1.9	2	2.2	2.3	2.5	2.7	2.9	3
200	1	1.1	1.2	1.3	1.5	1.8	2	2.2	2.4	2.7	2.9	3.1	3.3	3.6	3.8	4
250	1.3	1.4	1.6	1.7	1.9	2.3	2.5	2.7	3	3.4	3.7	3.9	4.2	4.5	4.8	5
300	1.5	1.7	1.9	2	2.3	2.7	3	3.3	3.7	4	4.4	4.7	5	5.3	5.7	6
350	1.7	2	2.2	2.4	2.7	3.1	3.6	3.9	4.3	4.7	5.1	5.5	5.9	6.2	6.6	7
400	2	2.2	2.5	2.7	3.2	3.6	4.1	4.4	4.9	5.3	5.8	6.2	6.7	7.1	7.6	8
450	2.3	2.5	2.8	3	3.5	4	4.6	5	5.6	6	6.5	7	7.5	8	8.5	9
500	2.5	2.8	3.1	3.3	3.8	4.4	5	5.6	6.2	6.7	7.3	7.8	8.4	8.9	9.5	10
600	3	3.3	3.7	4	4.6	5.3	6	6.7	7.4	8	8.7	9.3	10	10.7	11.4	12
700	3.5	3.9	4.3	4.7	5.4	6.2	7	7.8	8.6	9.3	10.2	10.9	11.7	12.4	13.2	14
800	4	4.4	4.9	5.3	6.2	7.1	8	8.9	9.8	10.7	11.6	12.4	13.4	14.2	15.2	16
900	4.5	5	5.5	6	6.9	8	9	10	11	12	13	14	15	16	17	18
1000	5.1	5.6	6.2	6.7	7.7	8.9	10	11.1	12.3	13.3	14.5	15.6	16.7	17.8	18.9	20

FACTOR Z - HP REQUIRED TO LIFT OR DROP MATERIAL AT ANY SPEED VERTICALLY

Table 11.9

TPH	VERTICAL LIFT OR DROP IN FEET															
	5	10	15	20	25	30	35	40	45	50	55	60	70	80	90	100
50	0.3	0.5	0.8	1	1.3	1.5	1.8	2	2.3	2.5	2.8	3	3.5	4	4.6	5.1
100	0.5	1	1.5	2	2.5	3	3.5	4	4.5	5.1	5.6	5.1	7.1	8.1	9.1	10.1
150	0.8	1.5	2.3	3	3.8	4.5	5.3	6.1	6.9	7.6	8.4	9.1	10.6	12.1	13.7	15.2
200	1	2	3	4	5.1	6.1	7.1	8.1	9.1	10.1	11.1	12.1	14.2	16.2	18.1	20
250	1.3	2.5	3.8	5.1	6.3	7.6	8.9	10.1	11.4	12.6	13.9	15.2	17.6	20	23	25
300	1.5	3	4.5	6.1	7.6	9.1	10.6	12.1	13.7	15.2	16.7	18.2	21.1	24	27	30
350	1.8	3.5	5.3	7.1	8.8	10.6	12.3	14.1	15.9	17.7	19	21	25	28	32	35
400	2	4	6.1	8.1	10.1	12.1	14.1	16.2	18	20	22	24	28	32	36	40
450	2.3	4.5	6.8	9.1	11.4	13.6	15.9	18.2	21	23	25	27	32	36	41	45
500	2.5	5.1	7.6	10.1	12.6	15.2	18	20	23	25	28	30	35	40	46	51
600	3	6.1	9.1	12.1	15.2	18.2	21	24	27	30	33	36	42	48	55	61
700	3.5	7.1	10.6	14.1	17.7	21	25	28	32	35	39	42	50	57	64	71
800	4	8.1	12.1	16.2	20	24	28	32	36	40	44	48	57	65	73	81
900	4.5	9.1	13.6	18.2	23	27	31	36	40	45	50	55	64	73	82	91
1000	5.1	10.1	15.2	20	25	30	35	40	46	51	56	61	71	81	91	101.2

CONVEYOR DESIGN INFORMATION

ELECTRICAL FORMULAS

Table 11.10

TO FIND	ALTERNATING CURRENT		TO FIND	ALTERNATING OR DIRECT CURRENT
	SINGLE-PHASE	THREE-PHASE		
Amperes when horsepower is known	$\frac{Hp \times 746}{E \times \text{Eff} \times \text{pf}}$	$\frac{Hp \times 746}{1.73 \times E \times \text{Eff} \times \text{pf}}$	Amperes when voltage and resistance is known	$\frac{E}{R}$
Amperes when kilowatts are known	$\frac{Kw \times 1000}{E \times \text{pf}}$	$\frac{Kw \times 1000}{1.73 \times E \times \text{pf}}$	Voltage when resistance and current are known	IR
Amperes when Kva are known	$\frac{Kva \times 1000}{E}$	$\frac{Kva \times 1000}{1.73 \times E}$	Resistance when voltage and current are known	$\frac{E}{I}$
Kilowatts	$\frac{1 \times E \times \text{pf}}{1000}$	$\frac{1.73 \times 1 \times E \times \text{pf}}{1000}$	GENERAL INFORMATION (Approximation) At 1800 rpm, a motor develops 36 lb-in per hp At 1200 rpm, a motor develops 54 lb-in per hp At 575 volts, a 3-phase motor draws 1 amp per hp At 460 volts, a 3-phase motor draws 1.25 amp per hp At 230 volts, a 3-phase motor draws 2.5 amp per hp At 230 volts, a single-phase motor draws 5 amp per hp At 115 volts, a single-phase motor draws 10 amp per hp	
Kva	$\frac{1 \times E}{1000}$	$\frac{1.73 \times 1 \times E}{1000}$		
Horsepower = (Output)	$\frac{1 \times E \times \text{Eff} \times \text{pf}}{746}$	$\frac{1.73 \times 1 \times E \times \text{Eff} \times \text{pf}}{746}$		

All Values At 100% Load

I = Amperes; E = Volts; Eff = Efficiency; pf = power factor; Kva = Kilovolt amperes; Kw = Kilowatts; R = Ohms.

TEMPERATURE CONVERSION:
 Deg C = (Deg F - 32) x 5/9 Deg F = (Deg C x 9/5) + 32

AC MOTOR RECOMMENDED WIRE SIZE

Table 11.11

VOLTS	MOTOR HORSEPOWER																					
	1-3	5	7.5	10	15	20	25	30	40	50	60	75	100	125	150	200	250	300	350	400	450	500
230	14	12	10	8	6	4	3	1	0	0	0	300	500	0	300	500	700	900	1500	600*	750*	900*
460	14	14	14	12	10	8	6	6	4	3	2	0	0	0	0	250	500	600	800	1000	1500	600*
575	14	14	14	14	12	10	8	6	6	4	3	2	0									
2300																	6	4	3	2	1	1

*Parallel, use high voltage cable

MOTOR AMPS (A FULL LOAD †)

Table 11.12

HP	ALTERNATING CURRENT			HP	ALTERNATING CURRENT			HP	ALTERNATING CURRENT			HP	ALTERNATING CURRENT		
	SINGLE PHASE	THREE PHASE	DC		SINGLE PHASE	THREE PHASE	DC		SINGLE PHASE	THREE PHASE	DC		SINGLE PHASE	THREE PHASE	DC
1/2	4.9	2	2.7	5	28	14.4	20	25		60	92	75		180	268
1	8	3.4	4.8	7-1/2	40	21	29	30		75	110	100		240	355
1-1/2	10.1	4.8	6.6	10	50	26	38	40		100	146	125		300	443
2	12	6.2	8.5	15		38	56	50		120	180	150		360	534
3	17	8.6	12.5	20		50	74	60		150	215	200		480	712

† Values are for all speeds and frequencies (a 230 volts.)

Amperage other than 230 volts can be figured:

$$V = \frac{230 \times \text{Amp from table}}{\text{New voltage}}$$

Example: For 60 hp 3 phases (a 550 volts) $\frac{230 \times 150}{550} = 62$ Amps
 Power factor estimated (80% for most motors) Efficiency is usually 80-90%.

NEMA ELECTRICAL ENCLOSURE TYPES

Table 11.13

TYPE	DESCRIPTION	TYPE	DESCRIPTION
NEMA Type 1 (General Purpose)	For indoor use wherever oil, dust or water is not a problem.	NEMA Type 5 Dust Tight (Non-Hazardous)	Used for excluding dust. (All NEMA 12 and JIC enclosures are usually suitable for NEMA 5 use.)
NEMA Type 2 (Driptight)	Used indoors to exclude falling moisture and dust.	NEMA Type 9 Dust Tight (Hazardous) ‡	For locations where combustible dusts are present.
NEMA Type 3 (Weatherproof)	Provides protection against rain, sleet and snow.	NEMA Type 12 (Industrial Use)	Used for excluding oil, coolant, flying dust, lint, etc.
NEMA Type 4 (Watertight) †	Needed when subject to great amounts of water from any angle (such as areas which are repeatedly hosed down).		

Note: Joint Industry Conference (JIC) enclosures are similar in design to NEMA 12's. For complete details see NEMA or JIC Standards for enclosures.

† Not designed to be submerged.
 ‡ Class II Groups E,F, and G.

CONVEYOR DESIGN INFORMATION

CONVEYOR BELT TROUBLESHOOTING GUIDE

Table 11.14

PROBLEM	PROBABLE CAUSES - FROM MOST LIKELY TO LEAST								PROBLEM	PROBABLE CAUSES - FROM MOST LIKELY TO LEAST							
	7	14	15	17	20	-	-	-		20	15	5	19	21	22	9	-
Belt runs off at tail pulley	7	14	15	17	20	-	-	-	Excessive bottom cover wear	20	15	5	19	21	22	9	-
Belt runs off at all points of the line	25	17	14	20	3	16	-	-	Excessive edge wear, broken edges	25	3	17	9	1	20	2	-
One belt section runs off at all points of the line	2	11	1	-	-	-	-	-	Excessive top over wear, gouges, rips, ruptures, and tears	12	24	17	15	9	5	-	-
Belt runs off the head pulley	14	22	20	16	-	-	-	-	Cover swells or softens in spots	9	-	-	-	-	-	-	-
Belts runs to one side throughout the entire length at specific idlers	14	16	20	-	-	-	-	-	Longitudinal grooving or cracking of top cover	26	15	20	12	-	-	-	-
Belts slips	19	7	20	15	22	-	-	-	Cover checked or brittle	9	-	-	-	-	-	-	-
Belt slips on starting	19	7	22	10	-	-	-	-	Belt hardens or cracks	9	23	22	-	-	-	-	-
Excessive belt stretch	13	10	20	6	8	9	-	-	Longitudinal grooving or cracking of bottom cover	15	20	22	-	-	-	-	-
Belt breaks at or behind fasteners, or fasteners tear loose	2	23	13	22	21	10	6	8	Fabric decay, carcass cracks, gouges, ruptures, soft spots	12	21	5	10	9	-	-	-
Vulcanized splice separation	23	10	20	14	19	2	-	-	Ply separation	13	23	11	9	4	-	-	-

- BELT BOWED:** Avoid telescoping belt rolls or storing them in damp locations. A new belt should straighten out when "broken in" or complete system must be reinspected.
- BELT IMPROPERLY SPLICED OR WRONG FASTENERS:** Use fasteners recommended by the manufacturer. Retighten after running for a short while. If improperly spliced remove old splice and resplice. Set up regular inspection schedule.
- BELT STRAINED (or elongated on one side):** Allow enough time for new belt to "break in". If belt does not break in properly or is not new, remove strained section and splice in new piece.
- BELT SPEED TOO FAST:** Reduce speed.
- BREAKER STRIP MISSING OR INADEQUATE:** When service is lost, install belt with proper breaker strip.
- COUNTERWEIGHT TOO HEAVY:** Recalculate weight and adjust counterweight accordingly. Reduce take-up tension to point of slippage; retighten slightly.
- COUNTERWEIGHT TOO LIGHT:** Recalculate weight and adjust counter weight or screw take-up accordingly.
- DIFFERENTIAL SPEED WRONG ON DUAL PULLEYS:** Make necessary adjustment and observe operation closely.
- DAMAGE BY ACIDS, CHEMICALS, OILS, OR DETERIORATION BY ABRASIVES, HEAT OR MILDEW:** Use belt designed for specific condition. For abrasive materials working into cuts and piles, repair with cold pack or with permanent repair patch. Seal metal fasteners or replace with vulcanized step splice. Enclose belt line for protection against rain, snow, or sun. Do not over lubricate idlers.
- DRIVE UNDERBELTED:** Recalculate maximum belt tensions and select correct belt. If line is over-extended, consider using two flight system with transfer point. If carcass is not rigid enough for load, install belt with proper flexibility when service is lost.
- EDGE WORN OR BROKEN:** (permitting moisture penetration and belt shrinkage on one side): Repair belt edge. Remove badly worn or out-of-square section and splice in new piece of belt.
- EXCESSIVE IMPACT OF MATERIAL ON BELT OR FASTENERS:** Use correctly designed chutes and baffles. Make vulcanized splices. Install impact idlers. Where possible, load fines first. Where material is trapped under skirts, adjust skirtboards to minimum clearance or install cushioning idlers to hold belt against skirts.
- EXCESSIVE TENSION:** Recalculate and adjust tension. Use vulcanized splice with recommended limits.
- IDLERS OR PULLEY SHAFT OUT OF SQUARE WITH CENTER LINE OF CONVEYOR:** Realign and install limit switches for greater safety. Check conveyor manufacturer's manual or guide.
- IDLERS FROZEN:** Free the idlers; then lubricate, but don't overdo it.
- IMPROPERLY PLACED IDLERS:** Relocate idlers or insert additional idlers spaced to support belt.
- IMPROPER LOADING:** Feed should be in direction of belt travel and at belt speed, centered on the belt. Control flow with feeders, chutes and skirtboards.
- IMPROPER STORAGE OR HANDLING:** Contact your representative for storage and handling tips.
- INSUFFICIENT TRACTION BETWEEN BELT AND PULLEY:** Increase wrap with snub pulleys. Lag drive pulley. In wet conditions use grooved lagging. Install correct cleaning devices on belt and centrifugal switch for safety.
- MATERIAL BUILD-UP (on pulleys and idlers):** Remove accumulation and install cleaning devices, scrapers, and inverted "V" decking.
- MATERIAL FALLING BETWEEN BELT AND PULLEY:** Use skirtboards properly. Remove accumulation.
- PULLEY LAGGING WORN:** Replace worn pulley lagging. Use grooved lagging for wet conditions. Repair loose bolts protruding.
- PULLEYS TOO SMALL:** Go to a larger diameter.
- RELATIVE LOADING VELOCITY TOO HIGH OR TOO LOW:** Adjust chutes or belt speed. Consider use of impact idlers. Observe operation closely.
- SIDE LOADING:** Load in direction of belt travel.
- SKIRTS INCORRECTLY PLACED:** Install skirtboards so that they do not rub against belt.

CONVEYOR DESIGN INFORMATION

DECIMAL AND METRIC EQUIVALENTS

Table 11.15

FRACTIONS OF AN INCH	EQUIVALENTS		FRACTIONS OF AN INCH	EQUIVALENTS	
	INCHES	MILLIMETERS		INCHES	MILLIMETERS
1/64	0.015625	0.396875	33/64	0.515625	13.096875
1/32	0.03125	0.79375	17/32	0.53125	13.49375
3/64	0.046875	1.190625	35/64	0.546875	13.890625
1/16	0.0625	1.5875	9/16	0.5625	14.2875
5/64	0.078125	1.984375	37/64	0.578125	14.684375
3/32	0.09375	2.38125	19/32	0.59375	15.08125
7/64	0.109375	2.778125	39/64	0.609375	15.478125
1/8	0.125	3.175	5/8	0.625	15.875
9/64	0.140625	3.571875	1/64	0.640625	16.271875
5/32	0.15625	3.96875	21/32	0.65625	16.66875
11/64	0.171875	4.365625	43/64	0.671875	17.065625
3/16	0.1875	4.7625	11/16	0.6875	17.4625
13/64	0.203125	5.159375	45/64	0.703125	17.859375
7/32	0.21875	5.55625	23/32	0.71875	18.25625
15/64	0.234375	5.953125	47/64	0.734375	18.653125
1/4	0.25	6.35	3/4	0.75	19.05
17/64	0.265625	6.746875	49/64	0.765625	19.446875
9/32	0.28125	7.14375	25/32	0.78125	19.84375
19/64	0.296875	7.540625	51/64	0.796875	20.240625
5/16	0.3125	7.9375	13/16	0.8125	20.6375
21/64	0.328125	8.334375	53/64	0.828125	21.034375
11/32	0.34375	8.73125	27/32	0.84375	21.43125
23/64	0.359375	9.128125	55/64	0.859375	21.828125
3/8	0.375	9.525	7/8	0.875	22.225
25/64	0.390625	9.921875	57/64	0.890625	22.621875
13/32	0.40625	10.31875	29/32	0.90625	23.01875
27/64	0.421875	10.715625	59/64	0.921875	23.415625
7/16	0.4375	11.1125	15/16	0.9375	23.8125
29/64	0.453125	11.509375	61/64	0.953125	24.209375
15/32	0.46875	11.90625	31/32	0.96875	24.60625
31/64	0.484375	12.303125	63/64	0.984375	25.003125
1/2	0.5	12.7	1	1	25.4

CONVEYOR BELT SPEEDS – PULLEY REVOLUTIONS PER MINUTE & FORMULAS

Table 11.16

DIA. OF PULLEY (INCHES)	PULLEY CIRCUMFERENCE (FEET)	BELT SPEEDS IN FEET PER MINUTE								
		100	150	200	250	300	350	400	500	600
12	3.14	31.8	47.7	63.7	79.6	95.6	111.4	127.3	159.2	191
14	3.67	27.2	40.8	54.5	68.2	81.7	95.5	109.1	136.4	163.7
16	4.18	23.9	35.8	47.8	59.8	71.8	85	95.5	119.4	143.2
18	4.72	21.1	31.8	42.4	53	63.6	74.2	84.9	106.1	127.3
20	5.24	19.1	28.6	38.2	47.7	57.2	66.8	76.4	95.5	114.6
24	6.28	16	23.9	31.9	39.8	47.8	55.7	63.7	79.7	95.5
26	6.8	14.7	22	29.4	36.7	44.2	51.5	58.8	73.5	88.1
28	7.32	13.7	20.5	27.3	34.2	41	47.8	54.7	68.3	81.9
30	7.85	12.7	19.1	25.5	31.8	38.2	44.6	51	63.7	76.4
32	8.37	11.9	17.9	23.9	29.8	35.8	41.8	47.7	59.7	71.6
36	9.42	10.6	15.9	21.2	26.5	31.8	37.2	42.5	53	63.7

PULLEY APPLICATION FORMULAS

Table 11.17

TO OBTAIN	HAVING	FORMULA
Belt speed feet per minute	Diameter (D) of pulley inches and revolutions per minute (RPM)	$S = 0.2618 \times D \times \text{RPM}$
Shaft speed revolutions per minute (RPM)	Velocity (S) ft. per minute and diameter (D) of pulley inches	$\text{RPM} = S \div 0.2618 \times D$
Diameter (D) of pulley inches	Velocity (S) ft. per minute and revolutions per minute (RPM)	$D = S \div 0.2618 \times \text{RPM}$
Torque (T) In. (Lbs.)	Force (W) lbs. and radius (R) inches	$T = W \times R$

TERMS AND CONDITIONS

SUPERIOR INDUSTRIES, LLC (d/b/a Superior Equipment and as Superior Components)

1. **OFFER AND ACCEPTANCE.** Superior Industries, LLCs ("Seller") acceptance of Buyer's order to purchase products is expressly made conditional on assent to these Terms and Conditions, which along with the Sales Order constitute a binding "Contract" between the parties. This Contract constitutes the complete and final agreement between Seller and Buyer for the products. Any additional or different terms or conditions contained in any document furnished by Buyer, including but not limited to, any purchase order or any acknowledgment, are deemed to be material and are hereby objected to and rejected by Seller. If such agreement shall be deemed an offer or counter-offer by Buyer, Seller expressly rejects such offer or counter-offer and limits acceptance to these Contract terms and expressly objects to any different or additional terms proposed by Buyer. Any actual performance by Buyer or Seller thereafter shall be deemed a renewal of the offer contained in this Contract and acceptance of this Contract without change. In the event of a conflict between the terms of this Contract and the terms of any other document, the terms of this Contract shall control. This offer to purchase Seller's products is valid for thirty (30) days from the date of the Sales Order.

2. **PAYMENT TERMS.** All prices specified in this Contract are FOB Seller's designated location which constitutes delivery. All risk of damage to or loss of the products from any cause whatsoever shall pass to Buyer upon delivery, even if Seller arranges for shipment of the product. Unless otherwise expressly provided on the reverse hereof, payment shall be made within thirty (30) days from the earlier of the date of delivery or the date of an invoice, without discount. Any discount which may be expressly provided on the reverse hereof applies to the sale price of the products at the shipping point, and does not apply to any charges made for taxes, storage, loading or transportation. All payments shall be made in United States dollars. Interest will be charged at the rate of eighteen percent (18%) per annum, or the maximum interest rate allowable by applicable law, whichever is lower, on all unpaid invoices. Buyer shall pay all taxes and charges of any nature imposed by any federal, state, or local governmental authority by reason of the sale or delivery of the products whether levied or assessed against Seller, Buyer, or the products. Such applicable taxes or charges, if not included in this Contract, shall be invoiced separately. If, in Seller's opinion, reasonable doubt exists as to Buyer's financial condition, Seller may, at any time and without prejudice to any other remedies, suspend or terminate performance of any order, decline to ship, stop any material in transit, or require full or partial payment by Seller in advance.

3. **DELIVERY.** Any delivery or promise date indicated on the Sales Order is an estimate of the date Seller believes the products will be available for delivery provided, however, Seller shall not be responsible for any delays in delivery.

4. WARRANTY.

a. **Limited Warranty; Exclusion of Third Party Components.** Subject to the terms, conditions and limitations contained herein, Seller warrants only to the original Buyer that (a) Seller's new equipment products and Seller's new component products will not fail to operate in accordance with their respective specifications due to defects in material or workmanship during the period which ends two (2) years from the date of delivery, normal wear and tear excluded, and (b) Seller's new equipment products will not incur a failure of their respective structural components (i.e., trusses) due to defects in material or workmanship at any time during the period which ends five (5) years from the date of delivery, normal wear and tear excluded. The foregoing periods are sometimes referred to as "original warranty periods." The foregoing limited warranty does not apply to any part, portion or component of any product which is manufactured by a third-party ("Third-Party Component").

b. **DISCLAIMER OF ALL OTHER WARRANTIES, EXPRESS, IMPLIED OR STATUTORY.** THE LIMITED WARRANTY SET FORTH IN THE FOREGOING PARAGRAPH IS THE SOLE AND EXCLUSIVE WARRANTY WITH RESPECT TO THE PRODUCTS. SELLER MAKES NO OTHER EXPRESS WARRANTY OF ANY KIND OR NATURE AS TO THE PRODUCTS OR THEIR PERFORMANCE EXCEPT FOR THOSE LIMITED WARRANTIES EXPRESSLY SET FORTH IN THE FOREGOING PARAGRAPH AND SPECIFICALLY DISCLAIMS ANY AND ALL REPRESENTATIONS OR WARRANTIES OF ANY KIND OR NATURE CONCERNING THE PRODUCTS, INCLUDING, BUT NOT LIMITED TO, ANY REPRESENTATION OR WARRANTY THAT THE PRODUCTS COMPLY WITH ANY LAW, RULE OR REGULATION. SELLER MAKES NO WARRANTIES WITH RESPECT TO ANY THIRD PARTY COMPONENT AND SELLER SPECIFICALLY SELLS SUCH THIRD-PARTY COMPONENTS "AS IS" WITHOUT ANY WARRANTY. FURTHER, SELLER MAKES NO IMPLIED WARRANTY OF ANY KIND OR NATURE WITH RESPECT TO ITS PRODUCTS OR ANY THIRD-PARTY COMPONENT AND SPECIFICALLY DISCLAIMS ANY AND ALL IMPLIED WARRANTIES, INCLUDING, BUT NOT LIMITED TO, ANY AND ALL IMPLIED WARRANTIES OF MERCHANTABILITY, FITNESS FOR A PARTICULAR PURPOSE, NON-INFRINGEMENT, OR COMPLIANCE WITH ANY FEDERAL, STATE OR LOCAL LAW, RULE OR REGULATION. IN ADDITION, SELLER EXPRESSLY DISCLAIMS TO THE FULLEST EXTENT ALLOWED BY LAW, RULE OR REGULATION ANY WARRANTY PROVIDED UNDER ANY FEDERAL, STATE OR LOCAL LAW, RULE OR REGULATION.

c. **Terms and Conditions of Warranty; Voiding of Warranty; Notice Requirements.** The limited warranties set forth above shall be null and void if (a) any alterations or modifications are made to a product, (b) a product is not maintained in strict compliance with the maintenance requirements set forth in the maintenance manual for such product or otherwise provided to Buyer of such product, (c) any repairs are made to a product which are not authorized by Seller in writing, (d) any failure of a product to comply with the above limited warranty is not reported to Seller in writing within thirty (30) days of the date such failure first occurs, (e) a product is operated after the failure of any warranty first occurs, (f) a product is used for any purpose other than for the purpose for which it was manufactured, (g) a product is not operated in strict compliance with the terms and conditions set forth in any operating manual for the product (including but not limited to exceeding the load bearing capacity of the product), (h) a product is abused or damaged, (i) Buyer fails to deliver the product to Seller for inspection and testing if requested by Seller or Buyer disposes of the product or any part or component on or before the sixtieth (60th) day after sending a written claim under the warranty to Seller, or (j) such failure of the limited warranty results from a failure of any Third-Party Component.

d. **Course of Dealing; Course of Performance; Usage of Trade.** No course of dealing or course of performance of Seller with respect to the products sold under this Contract or with respect to any of its products to whomever sold and no usage of trade shall be considered in interpreting this Contract or any part thereof and none of the foregoing shall be considered a waiver or modification of any such terms, conditions, disclaimers or limitation of the limited warranties or disclaimers contained in this Contract. No statement, whether written or oral, made by any employee, sales person, distributor, agent or contractor of Seller which is not set forth in this Contract shall be considered a representation or warranty with respect to any product, its specifications or its performance and all such statements are hereby disclaimed.

e. **Exclusive Remedies for Breach of Warranty.** The sole and exclusive remedy for any failure of any product to comply with the limited warranty set forth above or any other warranty imposed upon Seller by law, if any, shall, at the election of Seller, in its sole discretion, be either (a) the repair or replacement of the product or component which failed to comply with such warranty or (b) the refund of the purchase price of the product. Buyer is responsible for all labor costs in connection with the repair or replacement of any equipment or component product; however, Seller will be responsible for its own labor performed in connection with any repair of equipment products at Seller's location. Except as provided below, any repair or replacement shall carry the same warranty as the original product but only for the remainder of the original warranty period.

Buyer's exclusive remedy with respect to any claim arising out of or as a result of Third-Party Component shall be against the third-party manufacturer.

f. **Warranty Claims; Notice Requirement; Limited Time to Bring Claims.** Any and all claims under the above limited warranty shall be made to Seller only in writing and not later than thirty (30) days after the date the product first fails to comply with the above limited warranty but in no event later than the expiration of the original warranty period with respect to which the claim is being made. Any claim under the above limited warranty made after such period for making a claim shall be null and void. After receiving written notice of the warranty claim, Seller shall determine whether to (a) repair or replace the product or part or (b) refund the purchase price of the product. Seller may require Buyer to return any product or part thereof which Buyer claims to be defective to Seller at Buyer's cost for inspection as a condition to any claim under the above limited warranty. No product or part may be returned to Seller without Seller's prior written authorization. If a product which is returned is determined by Seller in its sole discretion not to have failed to comply with the limited warranty, Buyer shall pay costs of removal, repair and/or replacement for such product. If a product which is returned is determined by Seller in its sole discretion to have failed to comply with the limited warranty, Seller shall pay for all repair and/or replacement costs for such product (or refund the purchase price if so elected by Seller) and Seller shall reimburse Buyer for the reasonable costs of shipping the product or component to Seller.

g. **Limitation on Liability for Breach of Warranty and Other Claims.** If the warranty and the remedy for any failure of any product to comply with any warranty are deemed for any reason to fail their

TERMS AND CONDITIONS

intended purpose, Seller's liability for any failure of any product to comply with any such warranty, together with any and all other liability, if any, arising out of or in connection with such product, including, but not limited to, all claims, whether in contract, tort, or otherwise, arising out of, connected with, or resulting from the manufacture, sale, delivery, resale, repair, replacement, or use of the product, shall not exceed the purchase price for such product. In no event shall Seller be responsible or liable to Buyer or any third party under any circumstances for any indirect, consequential, special, punitive or exemplary, damages or losses, including, but not limited to, damages for loss of profits, goodwill, use of the product or any other equipment or other intangible losses which may be incurred in connection with the product regardless of the type of claim or the nature of the cause of action, even if Seller has been advised of the possibility of such damage or loss. Any and all claims that Buyer has against Seller, whether or not Buyer is aware of such claims, must be brought by Buyer within thirty (30) days after the date that such claim first arose, but in any event within the applicable warranty period set forth above. Any claim not brought by Buyer within the applicable thirty (30) day period shall be deemed null and void.

5. **INDEMNIFICATION.** Buyer will indemnify and hold harmless Seller, its affiliates and their respective officers, directors, employees, agents and other representatives and defend any action brought against same with respect to any claims, judgments, actions, suits, demands, damages, liabilities, costs or expenses (including, but not limited to, reasonable attorneys' fees and legal expenses) associated with or arising from the ownership, use or operation of the products by Buyer or any third party, including without limitation, product liability, an international, federal or state occupational safety and health statute, or any other governmental regulations or laws.

6. **TERMINATION OF PERFORMANCE.** Buyer may cancel its order only with the written consent of Seller and upon terms that will indemnify Seller from any loss, damage and expense arising from such cancellation. Seller may terminate this Contract pursuant to Sections 2 and/or 11 hereof, and in such event, Seller shall have no further liability to produce or ship any products hereunder and shall have no liability for damages to Buyer or any third party.

7. **TECHNICAL ADVICE.** No obligation or liability shall arise out of Seller's rendering of technical advice in connection with Buyer's order of products. Any technical advice furnished, or recommendation made by Seller or any employee or representative of Seller, concerning any use or application of any products or parts furnished under this Contract is believed to be reliable, but Seller makes no warranty, express or implied, of results to be obtained. Buyer assumes all responsibility for loss or damage resulting from the handling or use of any such products or parts in accordance with such technical advice or recommendation. The selection of the products ordered, or design of any custom products, shall be Buyer's sole and ultimate responsibility, and Seller shall have no liability whatsoever for any design defects of custom products, or if the products ordered are unsuitable for Buyer's intended use. Any advice or assistance provided by Seller to Buyer in connection with Buyer's selection or design of the products is at Buyer's risk, and Seller makes no representation or warranty whatsoever in connection with such advice or assistance.

8. **ASSIGNMENT.** Buyer shall not assign its rights or obligations under this Contract without the prior written consent of Seller, which consent may be withheld for any reason in the sole discretion of Seller. Any attempt at such assignment by Buyer without the prior written consent of Seller shall be deemed null and void. This Contract will be binding upon the parties hereto, and their successors and permitted assigns.

9. **SECURITY INTEREST OF SELLER.** Title to the products will not pass to Buyer until all required payments have been made to Seller. Until the purchase price and all other applicable costs and expenses are paid in full, Seller reserves a purchase money security interest in the products and the proceeds therefrom, and Seller thereby possesses the rights of a secured party under the Uniform Commercial Code. Upon Seller's request, Buyer shall execute all necessary financing statements and other documents evidencing this security interest with the appropriate state and local authorities. Seller is entitled to and is hereby granted reasonable access to Buyer's locations as necessary to exercise its remedies as a secured party.

10. **GOVERNING LAW.** This Contract shall be construed, interpreted, and governed by the laws of the State of Minnesota without regard to its conflict of laws principles. The exclusive forum for any disputes arising out of or relating to this Contract shall be any federal or state court sitting in the State of Minnesota. The parties irrevocably consent to such exclusive jurisdiction in such courts and to the proper venue therein.

11. **FORCE MAJEURE.** Seller does not assume the risk of and shall not be liable for failure to perform any obligation relating to the products caused by civil insurrection, war, fire, strike, labor stoppages or other labor disturbances, acts of God, acts or omissions of Buyer, acts or omissions of the United States Government, floods, epidemics, freight embargoes, shortages of fuel, energy or materials, failure of suppliers or subcontractors to satisfactorily meet scheduled deliveries, or any other cause beyond the reasonable commercial control of Seller.

12. **NOTICES.** Any notices, consents or other communications required or permitted under this Contract must be in writing and delivered personally, overnight air courier, registered or certified mail or facsimile. Unless otherwise stated in this Contract, notices, consents or other communication will be deemed received (a) on the date delivered, if delivered personally or by facsimile transmission; (b) on the next business day if sent via overnight air courier; or (c) three (3) business days after being sent, if sent by registered or certified mail.

13. **SEVERABILITY; WAIVER.** The invalidity or unenforceability of any provision of this Contract shall not affect the validity or enforceability of any other provision of this Contract. No waiver of any of the provisions of this Contract shall be deemed, or shall constitute a waiver of any other provision, whether or not similar, nor shall any waiver constitute a continuing waiver. No waiver shall be binding unless executed in writing by the party making the waiver. The Section headings included herein are for the convenience of the parties only and in no way alter, modify, amend, limit or restrict the contractual obligations of the parties.

14. **NO THIRD-PARTY BENEFICIARIES; SETOFF.** Nothing in this Contract is intended to, or shall, create any third-party beneficiaries, whether intended or incidental, and neither party shall make any representations to the contrary. Seller shall have the right to deduct from any sums it owes to Buyer, any sums or the value of any obligation owed by Buyer to Seller.

15. **ENTIRE AGREEMENT.** The terms set forth herein constitute the sole terms and conditions of the Contract between Buyer and Seller. Notwithstanding the foregoing or any other term of this Contract, to the extent this Contract conflicts with the terms or conditions of any written distributor agreement between the parties, the written distributor agreement shall control. No other warranty, term, condition or understanding, whether oral or written shall be binding upon Seller, unless hereafter expressed in writing, approved and signed by Seller.

16. **SURVIVAL.** The provisions of Sections 3, 4, 5, and 7 through 16 shall survive the termination and performance of this Contract.



superior-ind.com



NATIONAL STONE, SAND & GRAVEL ASSOCIATION



Natural building blocks for quality of life



Superior's welds are certified by the American Welding Society



ROCK FACE TO
LOAD OUT[™]

superior-ind.com

2026-02SPCT1098EN-14